

**SMART Gas Detector/Transmitter(4~20mA)  
with builtin TFT LCD & explosion proof**

# DA-600S-TOXI or O<sub>2</sub>

**Auto - Sampling Type**



**GASDNA Co.,Ltd** 101, Bukhang-ro 193beon-gil, Seo-gu, Incheon, 22856, Republic of Korea  
Tell: +82-32-584-7420 Fax: +82-32-584-7424 E-mail: sales@gasdna.com Web: www.gasdna.com

<http://www.gasdna.com>

■ 1. Product Introduction .....	3
■ 2. Product Features .....	4
■ 3. Product Specification .....	5
■ 4. Product Parts & Names .....	6~7
■ 5. Sensor Replacement .....	8
■ 6. Wiring .....	9
■ 7. Product Installation .....	10~11
■ 8. Device Operation .....	12~20
■ 9. MODBUS Registration Address .....	21~22
■ 10. Installation Precautions .....	23~29
■ 11. Gas Detection List .....	30

***Best Detectors,  
Best Service***

## 1. Product Introduction

The DA-600S-TOXI detector is an electrochemical detector that uses a full-color LCD and RGB LED to enhance visibility and warning indication.

The DA-600S-TOXI meter is a product suitable for measuring toxic gases using an electrochemical sensor. The DA-600S -TOXI sensor consists of a working electrode, a reference electrode, a counter electrode, and an electrolyte. When gas is exposed to the sensor, an electrochemical reaction occurs at the working electrode, causing oxidation or reduction, and this chemical reaction generates a microcurrent. This method detects this electric signal to measure the gas.

## 2. Product Features

- **Sampling Type**

By continuously sucking and detecting leaked gas with a micro pump, seamless gas detection becomes possible, even in challenging environments where traditional gas sensors are difficult to install or maintain.

- **Digital Process**

The built-in microprocessor-based digital processor implements various artificial intelligence functions to provide a convenient gas monitoring environment.

- **Non- Open Automatic Calibration Function**

The device's non-open automatic calibration function eliminates the need to open the detection unit cover during calibration. Instead, users can use a magnetic bar to touch the cover window, ensuring a safe and efficient calibration process, even in the explosive area.

- **Noise Blocking Circuit (Isolation Circuit)**

The stability of sensor output was strengthened by configuring an isolation circuit directly within the circuit to effectively block electrical noise.

- **User Programming**

The device allows users to customize various settings, such as the detection range and other functions, according to their specific requirements and preferences. This feature provides flexibility and adaptability to meet diverse monitoring needs.

- **Built-in HD (high resolution) A/D Converter:**

The device is equipped with a high-resolution analog-to-digital (A/D) converter, ensuring precise and accurate conversion of analog signals into digital output. This technology enhances the accuracy of the output signal, resulting in reliable and trustworthy measurements.

- **Analog 4-20mA Transmitter**

With the analog 4-20mA output, the device enables stable and long-distance signal transmission of up to 2.5 kilometers. This ensures reliable communication and allows for extended signal transmission distances while maintaining signal integrity.

- **Modbus RTU based on RS-485**

The Modbus RTU protocol, implemented over RS-485, provides a robust and dependable method for signal communication. With Modbus RTU, the device supports reliable, safe and long-distance signal transmission of up to 1.2 kilometers.

- **Alarm Output**

It is equipped with relay contact that provides a two-step alarm functionality (Alarm 1 & Alarm 2).

- **TFT Display**

2.4" color TFT display shows gas concentration in real time and is easy to read even in dark places.

### 3. Product Specifications:

Specification	Detail
Measuring Method	Sampling
Measuring Range	PPB, PPM, %VOL
Size	191(W) x 158(H) x 135(D)
Display	2.4" TFT LCD
Screen Size	48.96mm × 36.72mm(2.4inch)
Screen Display	5 magnetic switches with led confirmation
Warning light	RGB Color: RED, Orange & Green
Measuring Principle	Electrochemical
Measuring gas	See the gas list
Detection Time(T90)	>15 Sec
Input Power	DC 20~30V, Maximum power of 10Watts
External Outputs	4-20mA, Rs485 modbus, Relay x 2SPST(220V AC : 0.3A)
Ambient Temperatures & Humidity Range	-40°C ~ 55°C, 0 ~ 95% RH (Non-Condensing)
Mechanical interface	2 x 3/4"NPT
Certification	Ex db IIC T6 Gb(IP6X), Ex tb IIIC T85°C Db(IP6X)
Weight	3.8 Kg

## 4. Product Parts & Names

### 4.1 Internal Components of Detector

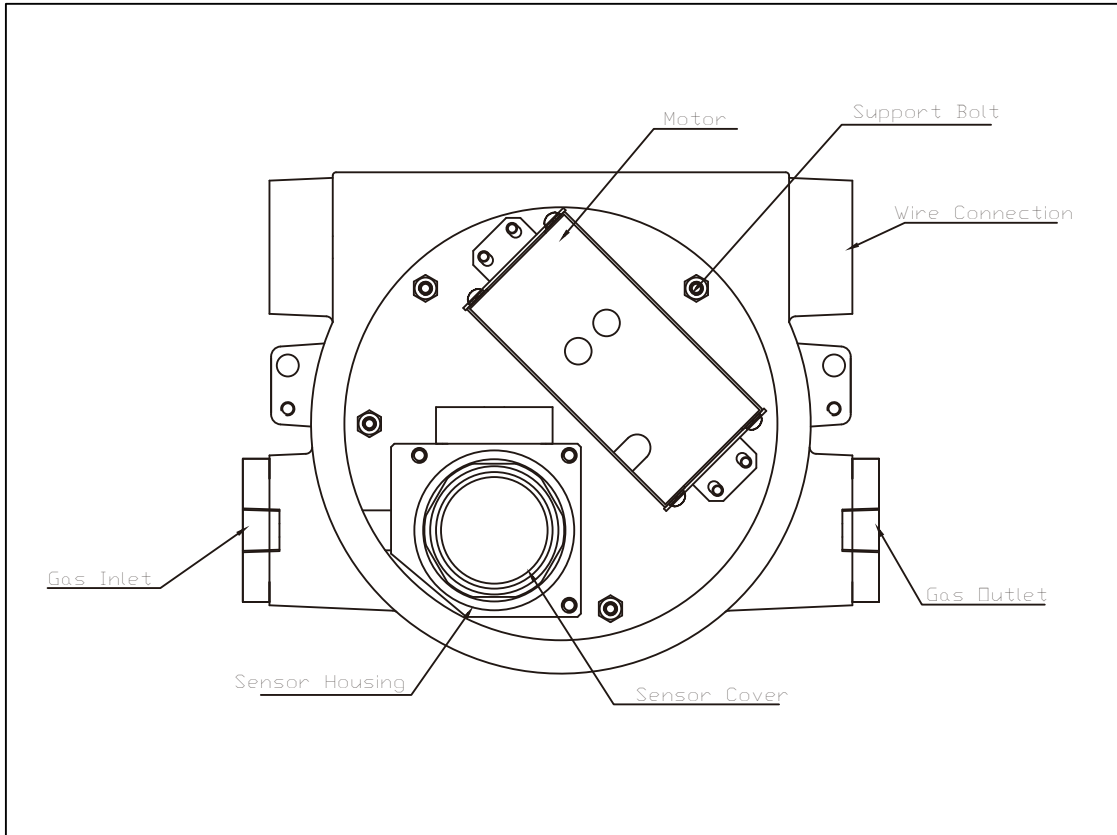

### 4.2 Function Module Board (TFT Display + Main Board)

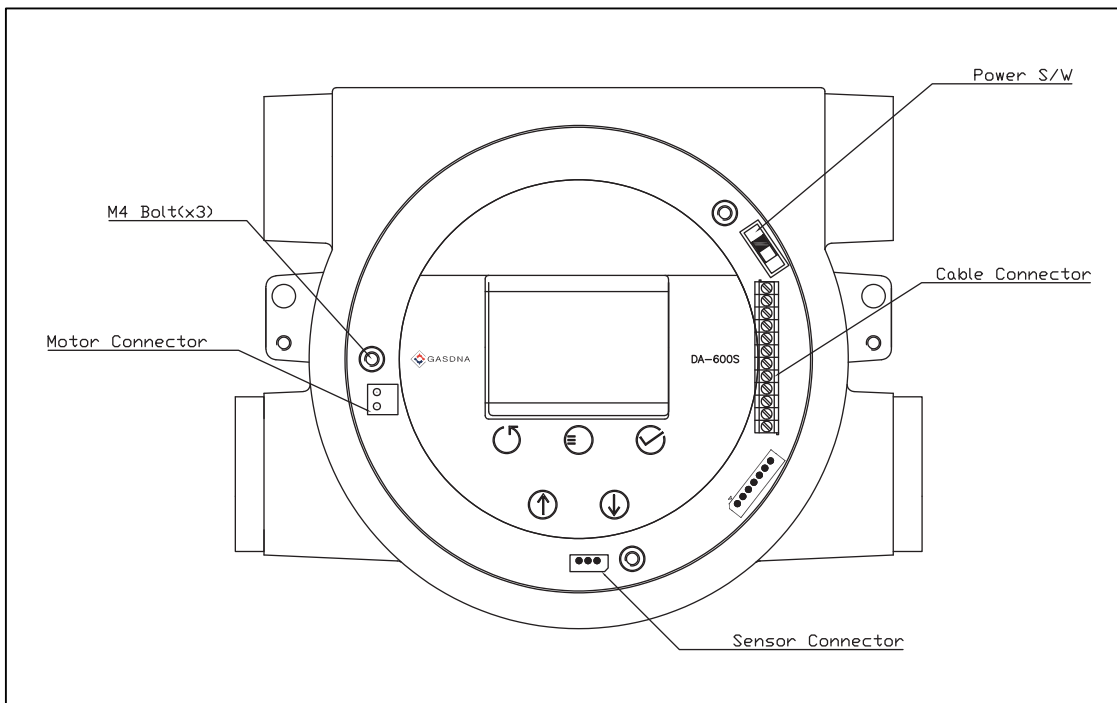

4.3 Each Part Names and Explanation

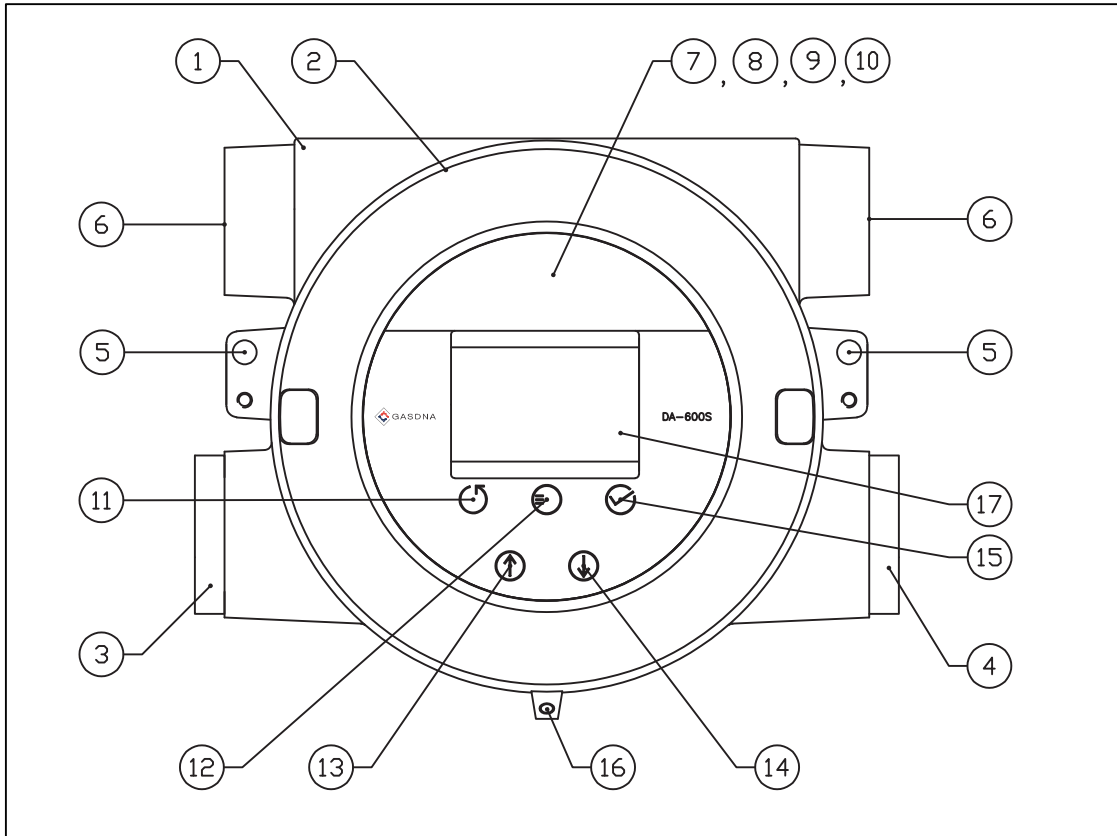

1. Detector Housing Body	10. AL-2 LED Light
2. Sensor Housing Cover	11. Reset Key
3. Gas Inlet (PT 1/4")	12. Mode Key
4. Gas Outlet (PT 1/4")	13. UP Key
5. MOUNT Whole	14. DOWN KEY
6. Pipe Connection	15. Enter Key
7. Power LED Light	16. DOWN KEY
8. Fault KED Light	17. HEADLESS Bolt (Housing Cover)
9. AL-1 LED Light	18. TFT Screen

\*Name Plate

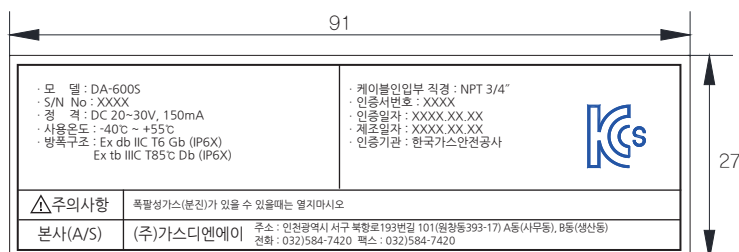

## 5. Sensor Replacement

The DA-600S sensor has an integrated structure with a sensor cap and sensor filter for sensor protection and explosion-proof functions. Therefore, sensor replacement work is done by replacing the sensor cap, which is an integrated structure with the sensor and filter. To replace the sensor, follow the following procedure, referring to the product configuration and name.

- ① Turn off the detector Power.
- ② Open the detector cover by rotating it anticlockwise.
- ③ Loose the four M4 bolts on the function module board and pull them out onto the support.
- ④ Disconnect the 3-wire sensor connector of Function Module.
- ⑤ Remove the mood bolt that is connected to the sensor housing anti clockwise and separate the sensor housing.
- ⑥ Combine the new sensor housing and connect it by tightening the headless bolt.
- ⑦ Connect the 3-wire sensor connector located on the power board.
- ⑧ To connect the function module board, push it accurately into the sidebar and tighten with two M3 bolts.
- ⑨ Turn the detector cover clockwise and tighten it tightly.
- ⑩ Turn On the Power
- ⑪ Start The Sensor Calibration Process.

### ▲ Caution

- Make sure the power is off before replacing the sensor.
- Make sure the connector's socket orientation is correct.
- Fully tighten the sensor cap and front cover to ensure waterproofing.



## 6.Wiring

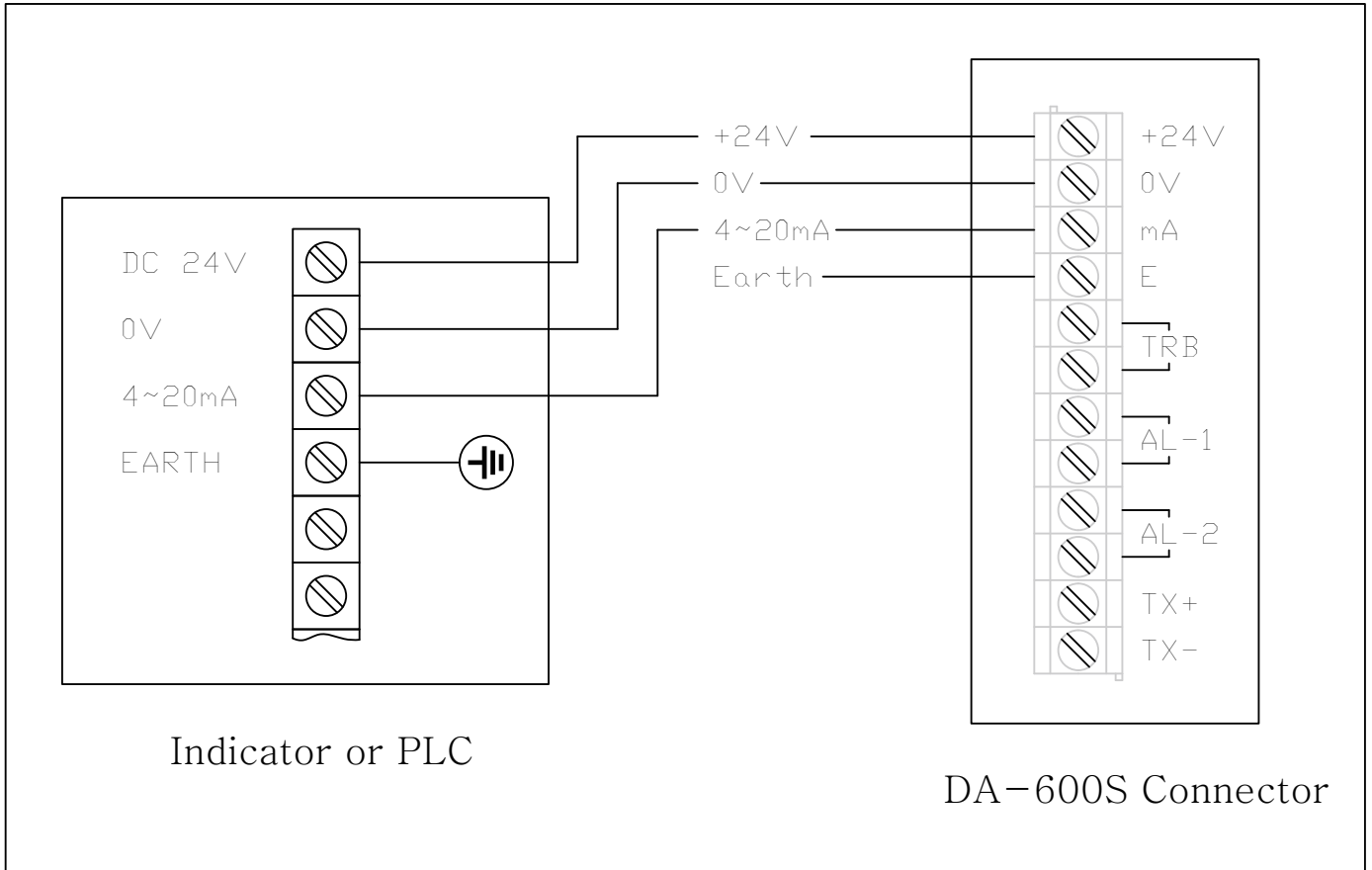

## 7. Product Installation

### 1. Front View

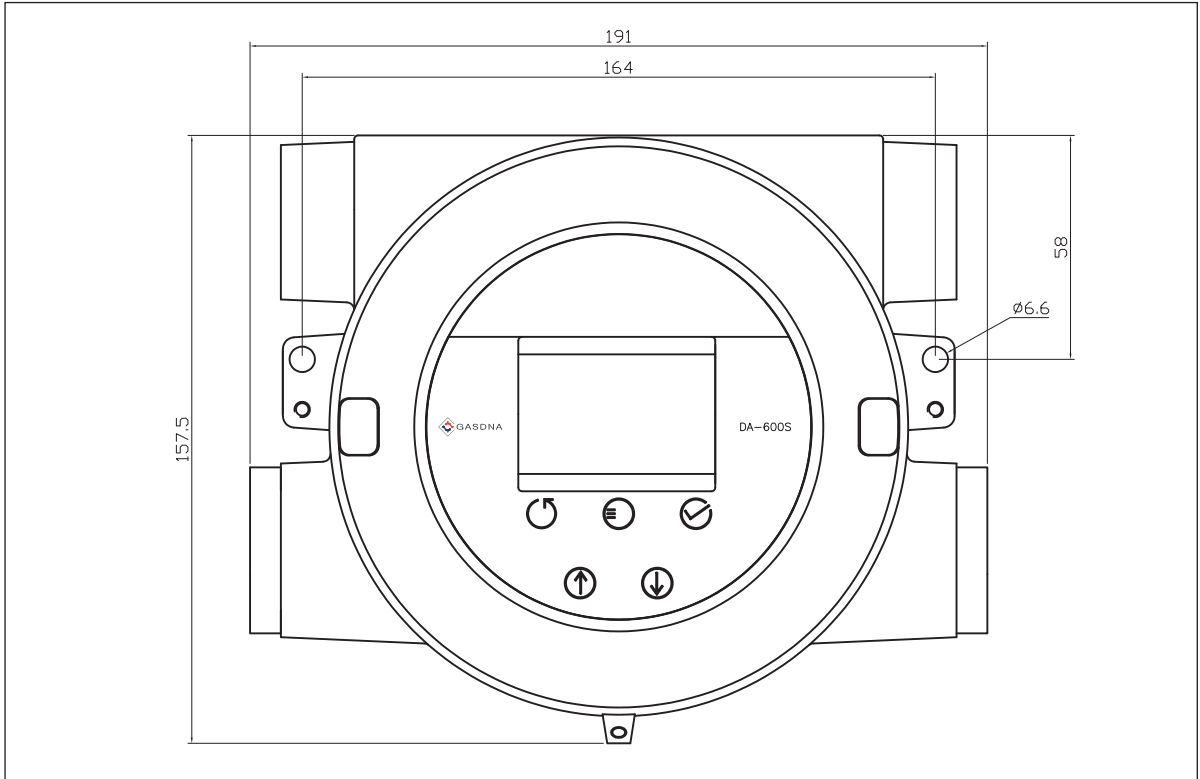

Unit: mm

### 2. Side View

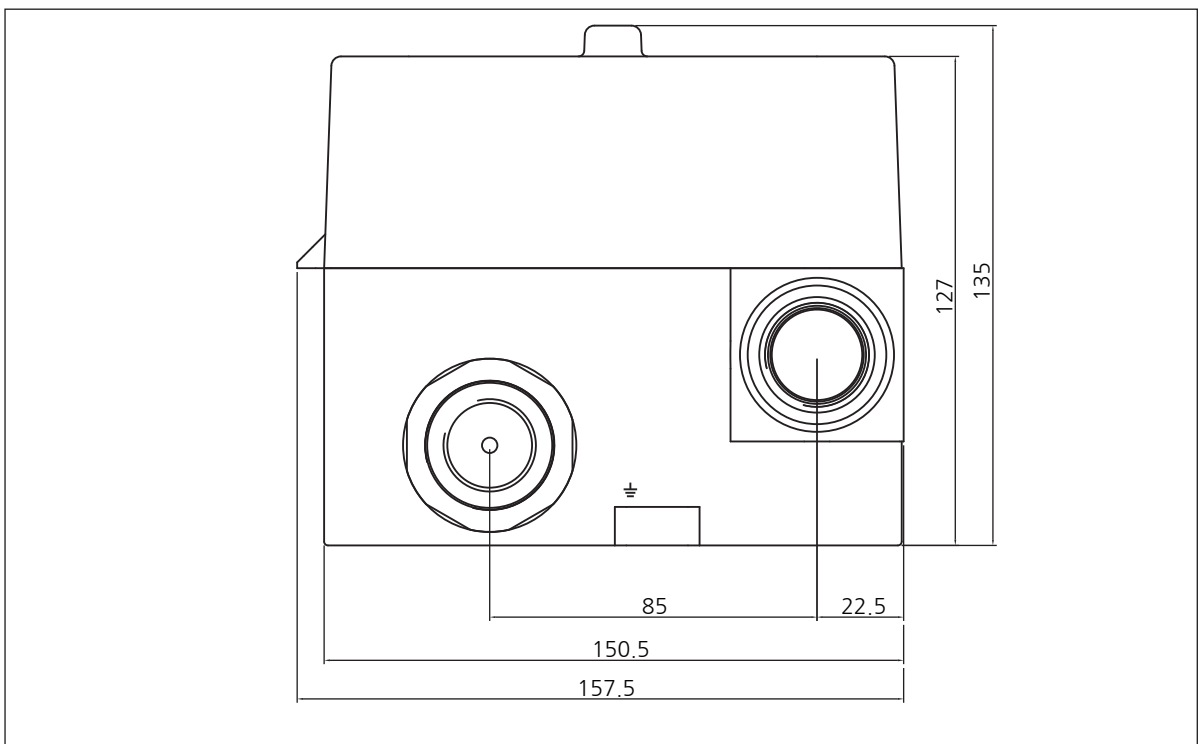

Unit: mm

#### Cable Conduit and Installation Location

- Cable Conduit: 3/4" PF/NPT
- In open areas, install the DA-600S as close as possible to potential gas leaks, such as gas valves and pipe connections.
- In closed areas,
  - Light Gas (Specific Gravity < 1): Install DA-600S 20~30 cm away from the ceiling.
  - Heavy Gas (Specific Gravity > 1): Install DA-600S 20~30 cm away from the floor.

#### ▲ Caution :

- Avoid potential electrical problems such as raindrops.
- Avoid vibration or physical shock that may affect the output signal value.
- Avoid high temperature or moisture.
- Avoid electrical noise such as motors, pumps or high voltage power lines.
- Please choose a location where repair and maintenance work can be easily performed. If this is not possible, it is recommended to use a suction type detector.

## 8. Device Operation

### 8.1 Startup Routine

When power is supplied, the DA-600S displays the following screen:

- Logo & Product Name screen







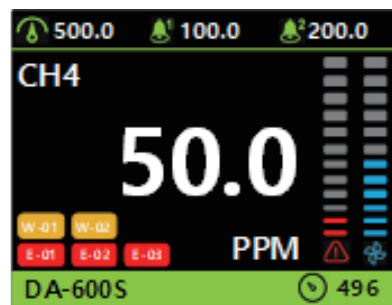

- Warming-up Screen: Before working in normal mode, the device must be warmed up so that the sensor output reaches a stable value. This preheating time can be skipped by pressing the DOWN key for 3 seconds.



- Normal measurement screen: After preheating, move to the normal measurement screen and display the measured concentration value.



<b>50.0</b>	Measured Concentration Value		Measured Concentration Value
<b>PPM</b>	UNIT		SUCTION Speed value level display
<b>CH4</b>	Gas Name		Pressure Value
<b>DA-600S</b>	ALARM 1 Operation (Setting Value 100.00)	<b>W-01</b>	In case of the measured value exceeds the MAX value
	Model Name	<b>W-02</b>	In case of pressure value is lower than the set value.
	ALARM 1 Operation(Setting Value 200.00)	<b>E-01</b>	In case of EEPROM error in MCU
	4~20 mA Communication HIGH SCALE Value	<b>E-02</b>	In case of ADC error in MCU
		<b>E-03</b>	In case of sensor connection error

## 8.2 Settings Menu

There are a total of 15 menus. To enter the menu settings, press the MODE key for 2 seconds.

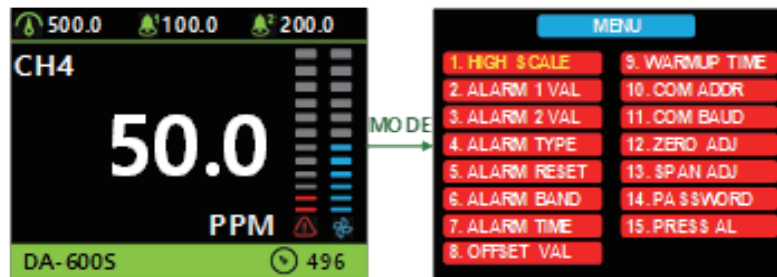

When the password status is ON, the password screen is displayed.

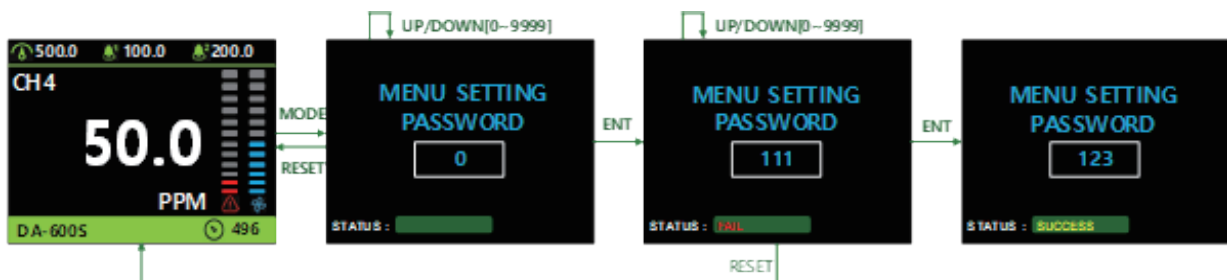

Change the password number using the UP and DOWN keys. Press the ENT key. If the password is correct, [SUCCESS] is displayed. If the password is incorrect, [FAIL] is displayed. Press RESET to return to the normal measurement screen.

Note: To access the menu regardless of your user password, enter the default password "1234".

### MENU 1: HIGH SCALE

Set the 4~20mA output signal to full scale. The current level is displayed.

EX: If HIGH SCALE is set to 100.0, the 4mA output signal is displayed as '0.0' and the 20mA output signal is displayed as '100.0'.

Note: Please refer to Table 2 for detailed 4-20mA output depending on the operation.

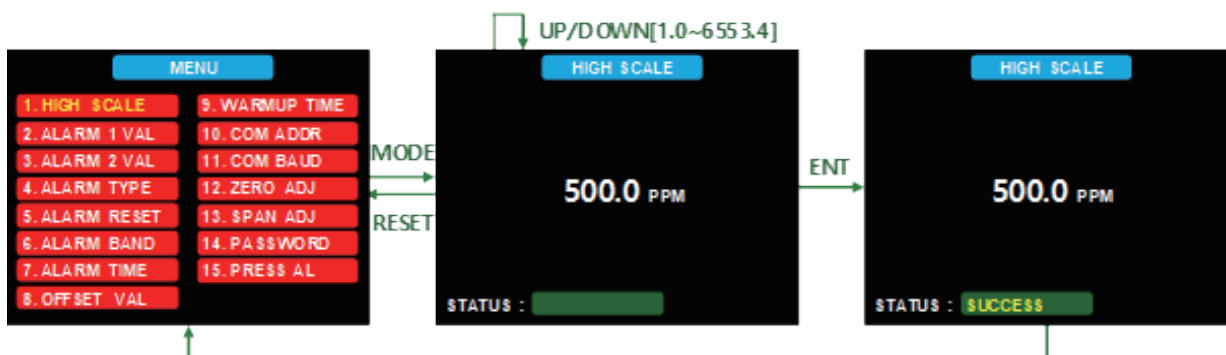

### MENU 2: ALARM 1 VAL

Set the alarm to level 1. Present level is displayed.

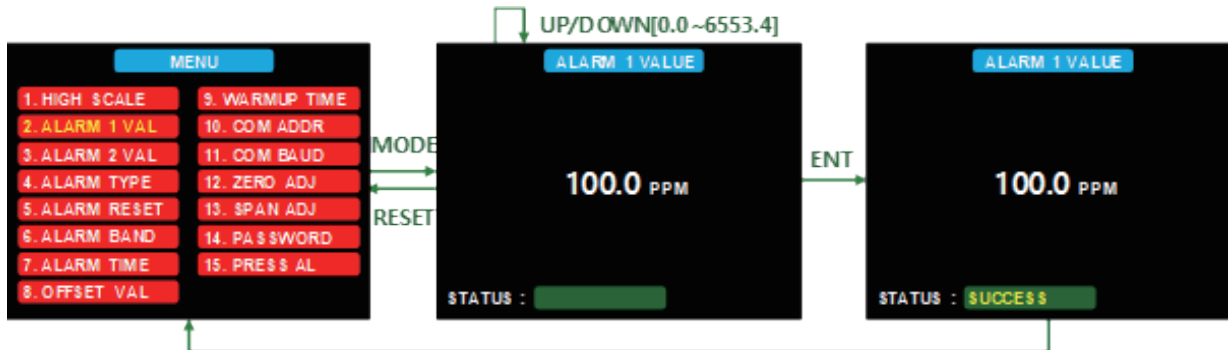

### MENU 3: ALARM 2 VAL

Set the alarm to level 1. Present level is displayed.

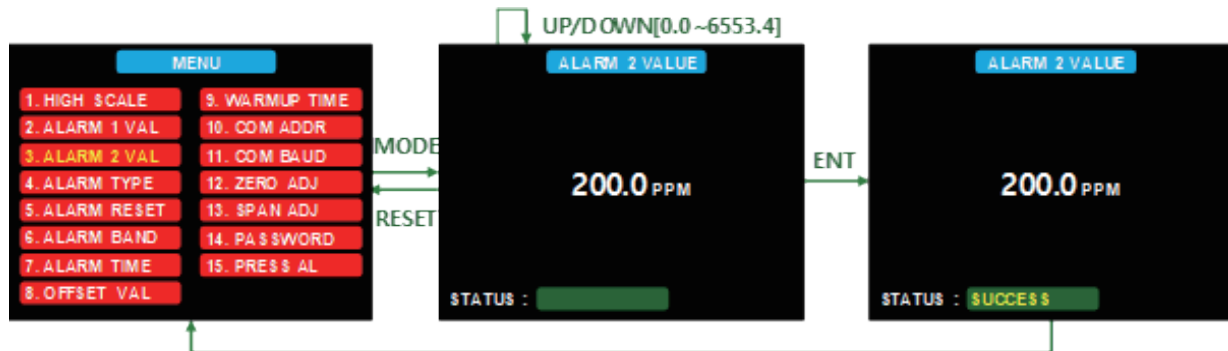

### MENU 4: ALARM TYPE

Set the alarm type for each alarm. There are four alarm types: HIGH-LOW, LOW-HIGH, LOW-LOW, HIGH-HIGH.

EX: In the case of HIGH-LOW: ALARM-1 corresponds to High Alarm, ALARM-2 corresponds to Low Alarm.

When an alarm occurs, the corresponding LED and relay are activated.

EX: In the case of ALARM-TYPE set to HIGH-LOW:

- If the measured value is higher than the alarm 1 level, the red LED blinks at a frequency of 2Hz and relay 1 is activated.
- If the measured value is lower than the alarm 2 level, the red LED blinks at a frequency of 4Hz and relay 2 is activated.

Note: Please refer to Table 1 for detailed LED status according to operation.

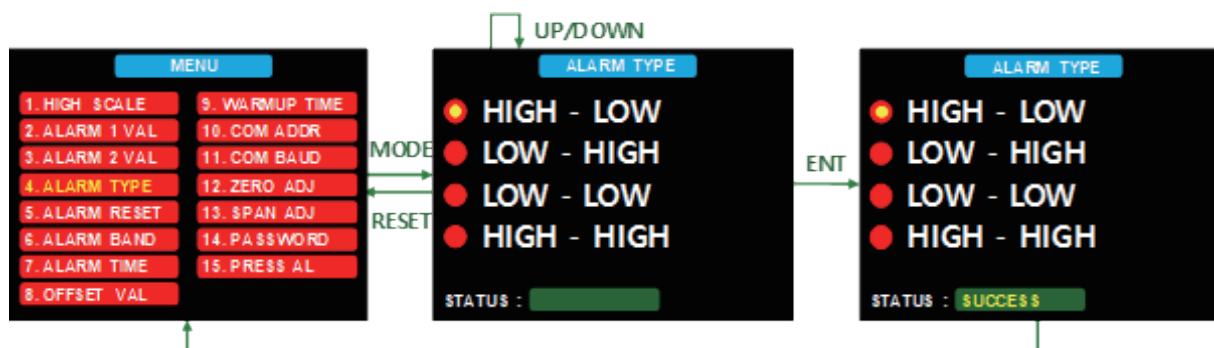

### MENU 5: ALARM RESET

Set the alarm release method.

- AUTO - Automatic: The alarm and relay are automatically released when the measured value goes beyond the predefined level according to the alarm type.
- MANUAL - Manual: The alarm and relay are released when the measured value goes beyond the predefined level according to the alarm type and the RESET key is pressed.

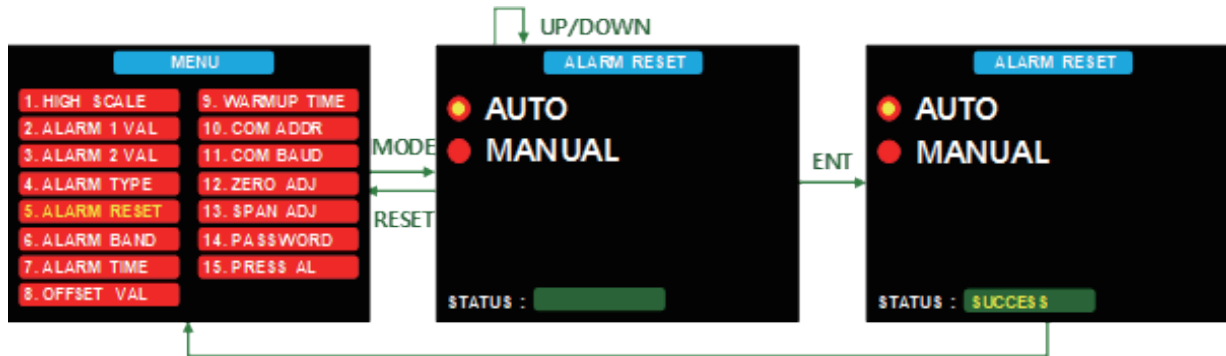

### MENU 6: ALARM BAND

Set alarm threshold to prevent repetitive alarms.

EX: If ALARM-1 is set to '20', ALARM-2 is set to '50', ALARM TYPE is set to 'HIGH-LOW', and ALARM BAND is set to '3', alarm 1 turns on when the measured value is greater than 20 and turns off when the measured value is less than 17.

Alarm 2 turns on when the measured value is less than 50 and turns off when the measured value is greater than 53.



### MENU 7: ALARM BAND

Set the alarm delay time to avoid influence by noise.

EX: If ALARM-1 is set to '50' and 'AL-TIME' is set to '5', the alarm will be activated only if the measured value remains higher than 50 for longer than '5' seconds.

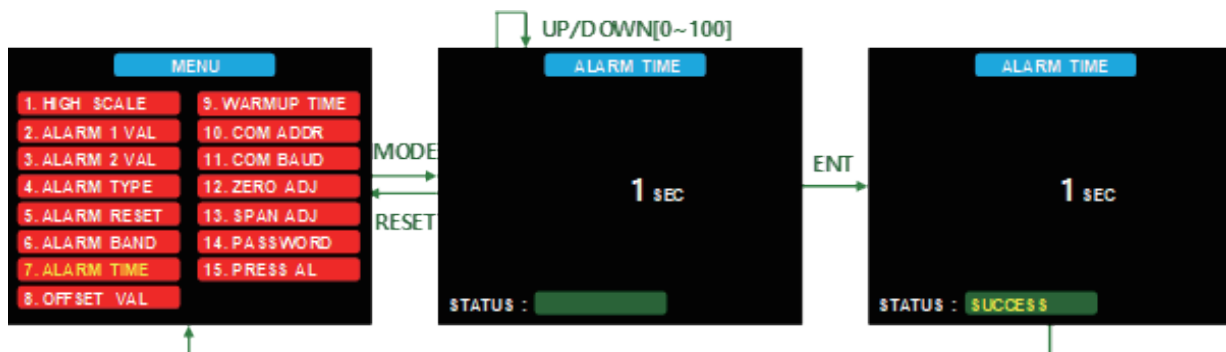

### MENU 8: OFFSET VAL

Set a value to compensate for the measurement.

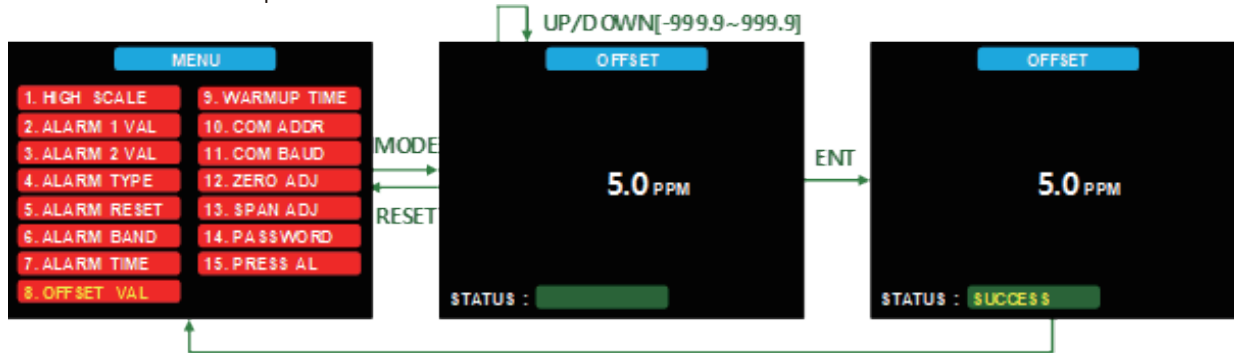

### MENU 9: WARMUP TIME

Set the initial time after Power On. This time is to ensure that the sensor output remains stable. (Can be set in minutes)

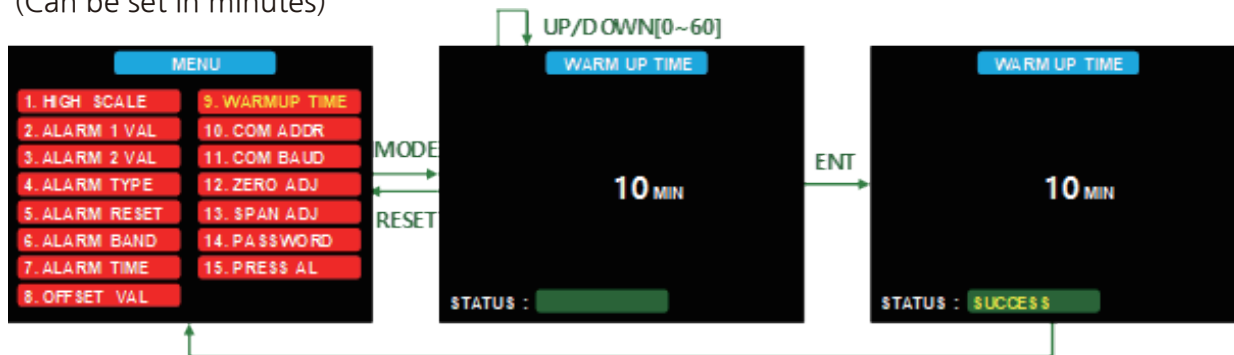

### MENU 10: COM ADDR

Setting the address for Modbus communication.

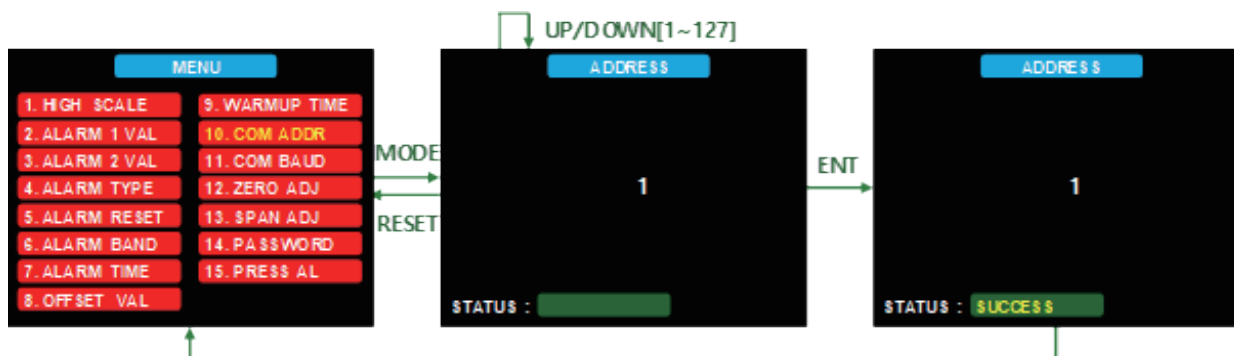

### MENU 11: COM BAUD

Setting the BAUD rate for Modbus communication.

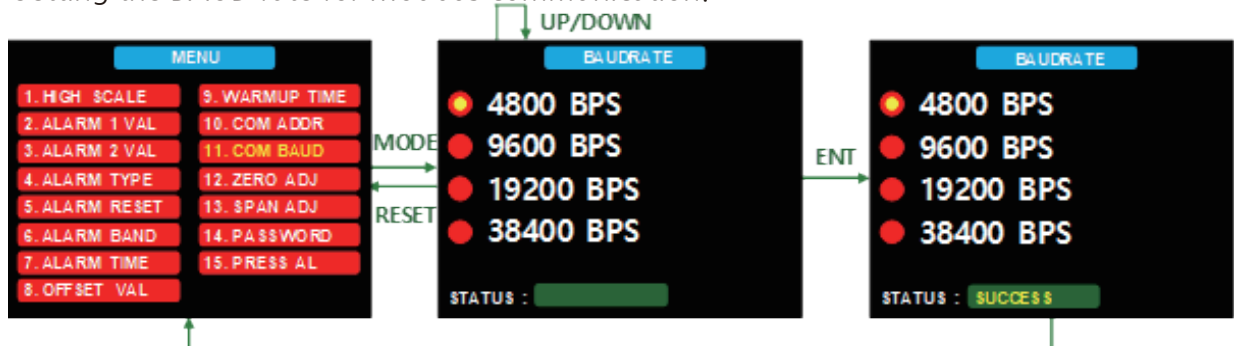



**MENU 12: ZERO ADJ**

ZERO ADJUST: Zero calibration

① You can enter zero point calibration by selecting the “ZERO ADJ” menu and entering the correct password. (Zero calibration password: 1)

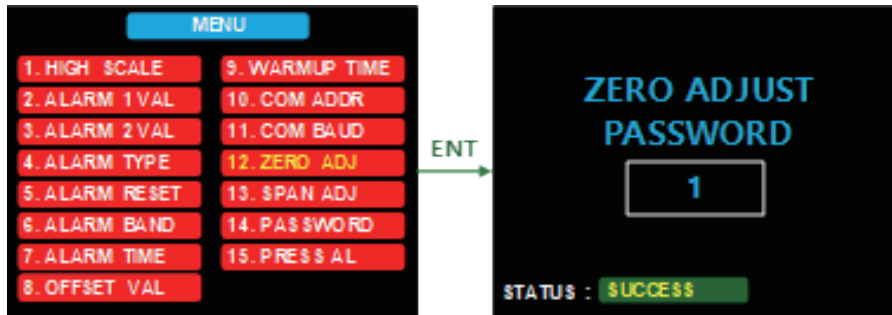

② Inject standard gas such as clean air or nitrogen gas for 1 minute. The current measured value and input value are displayed on the LCD. During calibration, the SUCTION speed can also be adjusted with the UP and DOWN keys.

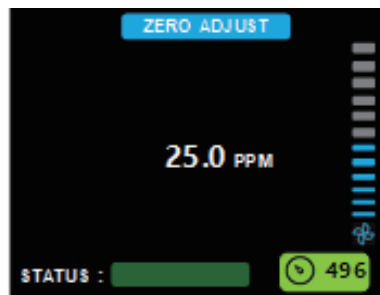

③ When the measurement value is stable, touch the ENT key. [PROCESSING] is displayed.

④ If the zero-calibration value is valid, [SUCCESS] is displayed. Then press the RESET key or MODE key to exit.

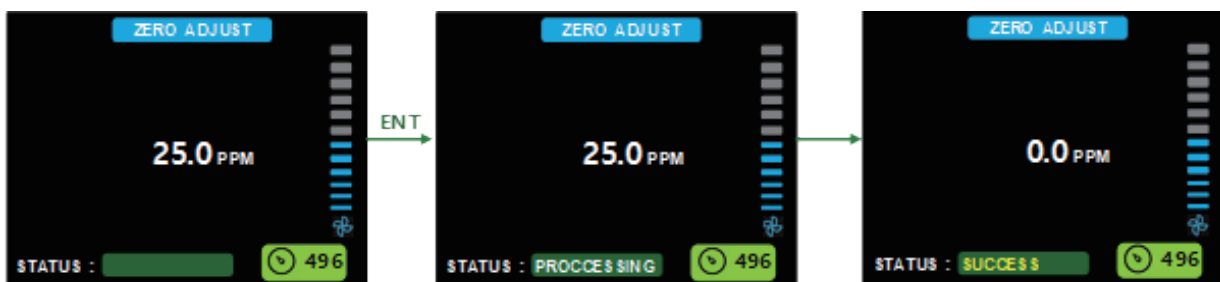

⑤ If the zero calibration value is invalid, [FAIL] is displayed.

⑥ In case of [FAIL], perform step 2 again. Otherwise, press the RESET key or MODE key to exit.

Note: Zero Calibration is performed with clean air or 99% nitrogen gas.  
(in case of O2 gas, 99.8% or higher nitrogen gas must be used.)

**MENU 13: SPAN ADJ**

SPAN ADJUST: Span Calibration

① Fix the calibration nipple to the sensor cap.

② Select the “SPAN ADJ” menu and enter the correct password for the span calibration. (Span Calibration Password: 2)

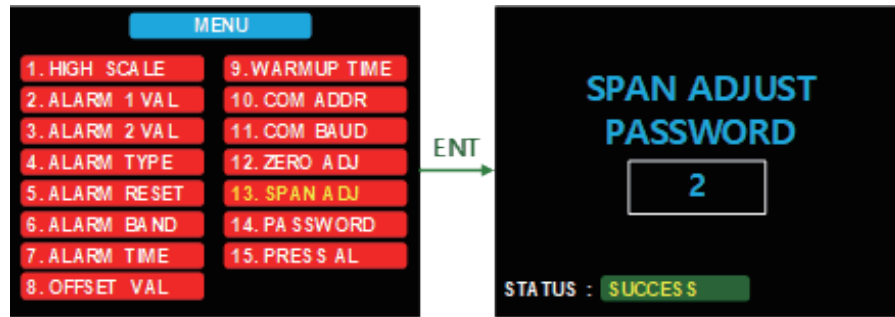

③ Press ENT to display the calibration density range. Press the UP and DOWN keys to enter the calibration gas density. Then press the ENT key to confirm.

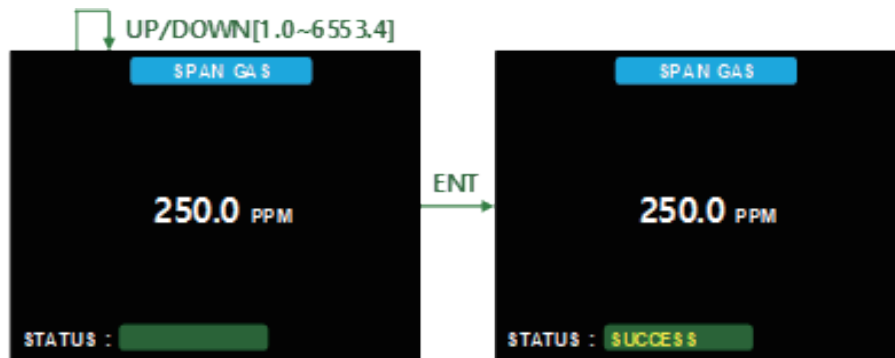

④ Then the screen automatically moves to SPAN ADJUST. Inject the standard gas and the current measured value is displayed on the LCD. During calibration, the SUCTION speed can also be adjusted with the UP and DOWN keys.

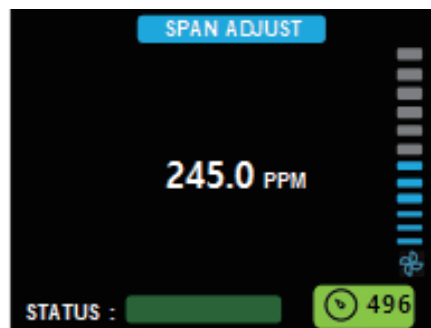

⑤ When the measurement value is stable, press the ENT key using the magnetic bar. The waiting time varies depending on the gas being measured (usually from 15 seconds to 5 minutes). If the span calibration value is valid, [SUCCESS] is displayed. Then, press the RESET key or MODE key to exit.

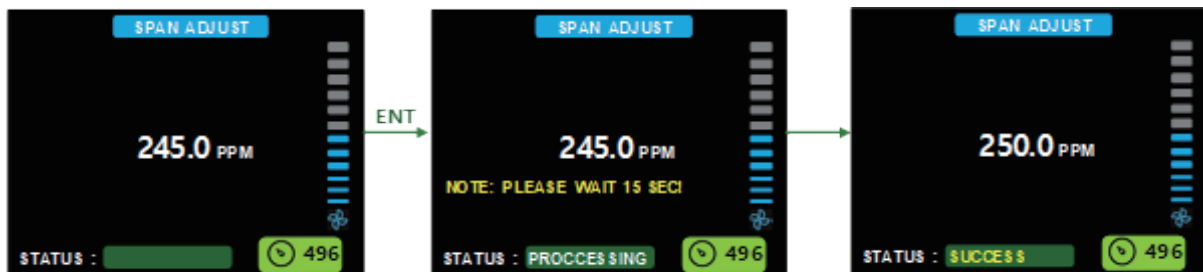

⑥ If the span correction value is invalid, [FAIL] is displayed:

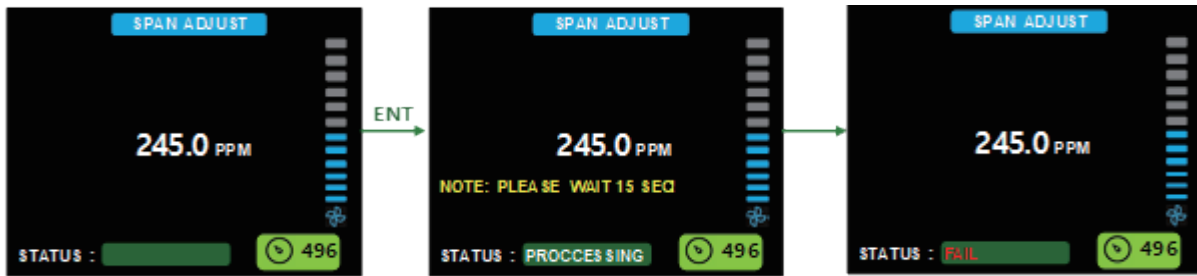

⑦ If [FAIL], repeat step 5. Otherwise, press the RESET key or MODE key to exit.  
Caution: After replacing the sensor, wait at least 10 minutes after turning on the power before starting the calibration.

### MENU 14: PASSWORD

Set a password to enter Product Menu.

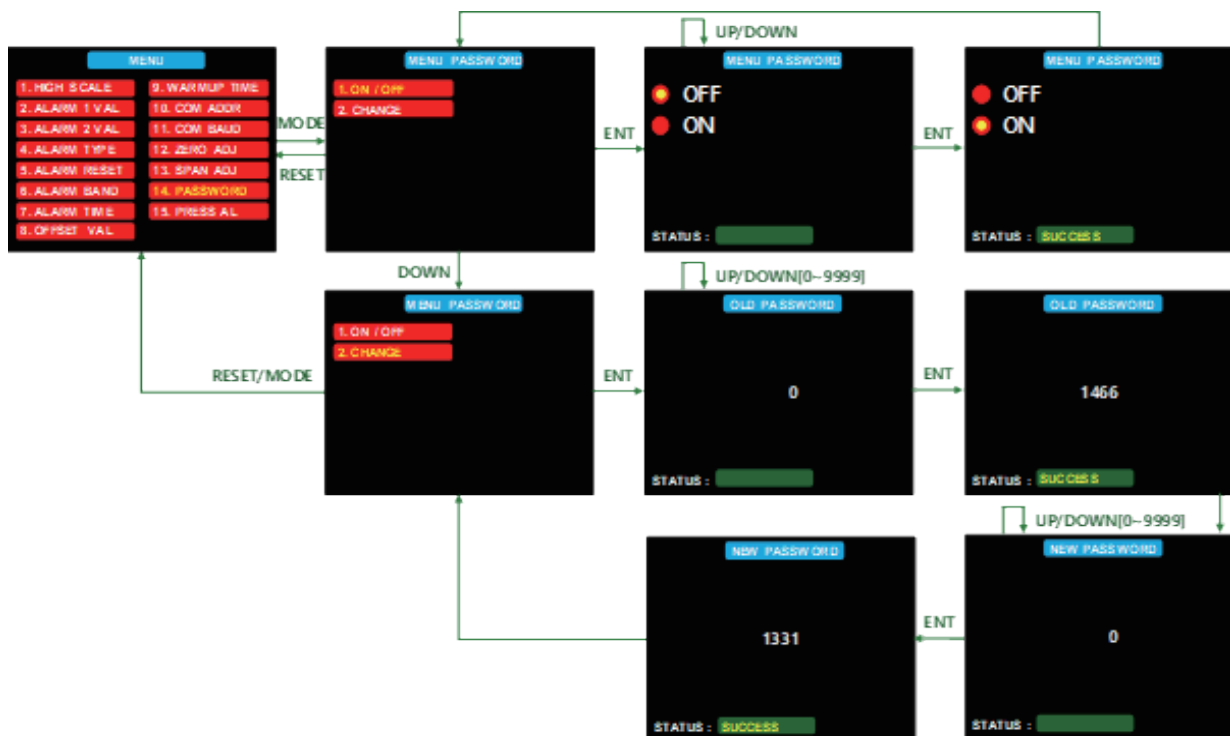

### MENU 15: PRESS AL

Set a low pressure warning value.

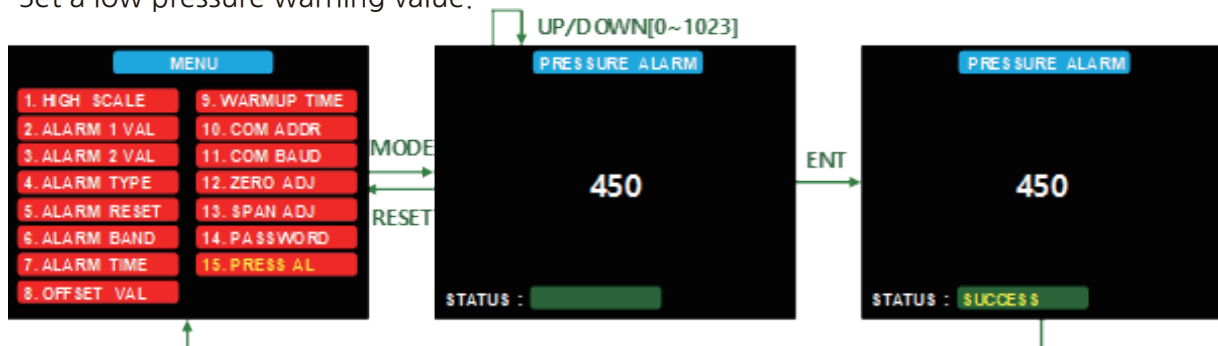

**Table 1: LED Status**

Status	Color	Frequency
Start	Blue ⇄ Red ⇄ Green	
Warm up	Yellow Color	Blink
Product Setting	Blue Color	Safe
Normal Measurement	Green Color	Safe
Alarm 1	Red Color	Blink 2Hz
Alarm 2	Red Color	Blink 4Hz
Error	Red Color	Safe

**Table 2: 4~20Ma Output**

Warm Up	4 MA
Normal Measurement	4~20 MA
Exceeded HIGH SCALE Value	21 MA
Error	2 MA

## 9. MODBUS Registration Address:

### 9.1 Register Input

Index	Register	Name	Content	Note
0	30001	Gas concentration	Gas concentration	
1	30002	Decimal point	0x0000 = No decimal point (ex: 12345) 0x0001 = First decimal point (ex: 1234.5) 0x0002 = Second decimal point (ex: 123.45) 0x0003 = Third decimal point (ex: 12.345)	BIT 0~7
		Unit	0x0000 = %Volume      0x0100 = %LEL 0x0200 = ppb              0x0300 = ppm	BIT 8~15 Ex) Second decimal point, ppm → 0x0302
2	30003	System status	0x0000: no error BIT 0 = 1: alarm 1 BIT 1 = 1: alarm 2 BIT 2 = 1: error BIT 3 = 1: warning	BIT 2 = 1, refer to [30004] BIT 3 = 1, refer to [30005]
3	30004	System error	0x0000: no error BIT 0 = 1: MCU EEPROM error BIT 1 = 1: MCU ADC error BIT 2 = 1: sensor error	
4	30005	System warning	0x0000: no warning BIT 0 = 1: over range BIT 1 = 1: pressure too low	
5~11	30006 ~30012	Reserved		
12	30013	Device name (1)	"DA"	BIT 15~8 = 'D' BIT 0~7 = 'A'
13	30014	Device name (2)	600	
14	30015	Device name (3)	'S'	
15	30016	Firmware version		Ex) "100" → version 1.00
16	30017	Real-time warming up counter		Unit second

## 9.2 Register Holding

Index	Register	Name	Content	Note
0	40001	Gas concentration	Gas concentration	Read only
1	40002	Decimal point	0x0000 = No decimal point (ex: 12345) 0x0001 = First decimal point (ex: 1234.5) 0x0002 = Second decimal point (ex: 123.45) 0x0003 = Third decimal point (ex: 1234.5)	BIT 0~7
		Unit	0x0000 = %Volume 0x0100 = %LEL 0x0200 = ppb 0x0300 = ppm	BIT 8~15 Ex) Second decimal point, ppm → 0x0302
2	40003	High scale	High scale for 4~20mA output	Range [0 ~ 65000], refer to [40002] decimal point
3	40004	Alarm 1 value		Range [0 ~ 65000], refer to [40002] decimal point
4	40005	Alarm 2 value		Range [0 ~ 65000], refer to [40002] decimal point
5	40006	Alarm type	0: Alarm 1: HIGH, Alarm 2: LOW 1: Alarm 1: LOW, Alarm 2: HIGH 2: Alarm 1: LOW, Alarm 2: LOW 3: Alarm 1: HIGH, Alarm 2: HIGH	
6	40007	Offset		Range [-9999 ~ 9999], refer to [40002] decimal point
7	40008	Alarm reset type	0: Auto 1: Manual	Manual mode: press RESET KEY to reset alarms
8	40009	Modbus Address		Range [1~127] Set [40011] = 1 to unlocked before change After change, set [40011] = 0
9	40010	Modbus Baudrate	0x0000 = 4800 BPS      0x0001 = 9600 BPS 0x0002 = 19200 BPS    0x0003 = 38400 BPS	Set [40011] = 1 to unlocked before change After change, set [40011] = 0
10	40011	Modbus lock	0x0000 = locked 0x0001 = unlocked	
11	40012	Warming up time setting		Unit: minute Range [0~60] minute
12	40013	Warming up force end	1: force end warming up counter	
13	40014	4~20mA output disable	0: enable 1: disable	
14	40015	4mA output set	Adjust output current to 4mA	Range [1~65534] Disable 4~20mA using [40014] before adjusting 4mA output After change, set [40014] = 0
15	40016	20mA output set	Adjust output current to 20mA	Range [1~65534] Disable 4~20mA using [40014] before adjusting 20mA output

## 10. Installation Precautions

1. In the event that the device experiences a significant impact or is accidentally dropped, it is essential to be cautious, as such incidents could potentially compromise its explosion-proof performance.
2. Whenever it becomes necessary to open the device for installation, inspection, maintenance, or any other related tasks, it is imperative to turn off the power beforehand. Furthermore, adequate security measures must be implemented to prevent any inadvertent supply of power while the device is open.
3. When opening or closing the device, be careful not to scratch the joint surface. Make sure that there is no dust or foreign matter attached to the joint surface, and when tightening bolts, you must use a tool to tighten them completely without missing a single bolt.
4. Do not open while energized.
5. Do not arbitrarily disassemble parts that affect explosion-proof performance.
6. Due to the non-sealed nature of the detection element in the detection unit, it is important to install it in a location that avoids exposure to potential electrical issues, such as rainwater. Regular maintenance is a necessity, so it is advisable to place the unit in a location that allows for easy access and convenient maintenance.
7. Places subject to vibration or impact may affect the output value, so avoid installing in places subject to vibration or impact.
8. This device features a pressure explosion-proof design, making it suitable for use in environments containing GROUP II and GROUP III gases, vapors, and dust, typically found in general workplaces and chemical plants. It has been certified for use in hazardous areas, including Zone 1, Zone 2, Zone 21, and Zone 22
9. When connecting this device and a conduit, ensure that there are more than 5 threads.
10. Ensure that work is conducted in accordance with the established standards for the selection, installation, and maintenance of explosion-proof structural electrical machinery and wiring, in order to maintain a safe workplace.
11. All bolts, nuts and washers used during assembly must be supplied by the manufacturer.
12. When connecting the power source, use the “O” type terminal to maintain the performance of the device, except in special cases.
13. The cable connection or terminal that extends from the product and connects to the power cable should utilize a junction box that has obtained separate certification.

14. When conducting wiring connections, it is crucial to employ an explosion-proof cable gland at the cable inlet. Alternatively, if metal conduit wiring is being carried out, the conduit should be sealed to avert the passage of gas and to inhibit flame propagation within a 50 mm radius in the event of an explosion. This sealing process is essential for safety.

- (Require tested and certified products like cable glands and sealing fittings for all cable entry materials.)

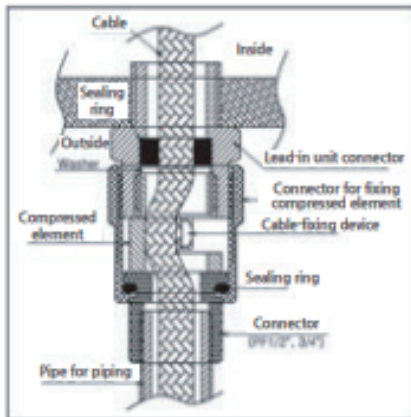

[Figure 1. High-Pressure Packing Type]

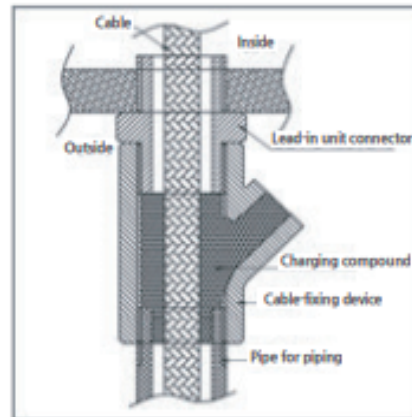

[Figure 2. Y Sealing Compound]

15. The allowable temperature falls below 85°C, which corresponds to T6.

16. Use in an ambient temperature range of -25°C to +70°C.

17. Relative humidity: % ~99%, installation location: outdoors and indoor.

18. “Caution - Use fasteners with a yield strength  $\geq$  stainless steel grade (A-70) for screws and nuts” (Minimum yield stress: 450 MPa)

- Reference: KS C IEC 60079-1 Table F.1 - Mechanical properties of screws and nuts



## Operation and Precautions

1. Operation method
  - A. Check the connection status of the cables installed on the product and the condition of the metal piping.
  - B. Apply power to the installed product.
  - C. Verify that it is operating normally.
2. Precautions
  - A. Be sure to read the user manual before using the product, and use and install it according to the prescribed methods.
  - B. This product must be installed by a qualified electrician.

## Supply Range

1. Supply includes: DA-600S complete (including grounding)
2. Supply Excludes:
  1. On-site handling, and storage
  2. Connection of external wires and grounding
  3. Connection of external wires and grounding

## Product Transportation

### A. Packing Method and Procedure

- While packaging the product, we ensure that the exterior is free from foreign substances, completely clean and dry, and apply appropriate anti-corrosion treatment to untreated areas.
- The packaging should be robust and suit the size and weight of the contents, we should not use the material like wheat, rice straw, or rice husk. Instead, use materials like air caps or newspapers to provide cushioning. Proper protection is crucial to prevent rust and corrosion since the product is corrosion-resistant."

### B. Transportation Method

- As a general practice, manufacturers are responsible for delivering their products directly or through designated transportation methods. In some cases, such as islands and mountainous regions, courier services may be employed. If equipment is lost, damaged, or if there's a deterioration in quality due to improper manufacturer packaging during transit, the manufacturer bears responsibility for any resulting issues
- When transporting the product, there is a risk of damage if it's thrown or stacked too high and subsequently falls due to its own weight. Therefore, it's essential to implement proper protective measures and equipment during transportation to prevent such damage.
- **Although we pack this product with the utmost care, sometimes products may be lost or damaged during transportation, so users are advised to check the condition of the products after receiving the product.**
- **If there is a defect in the contents, please contact us immediately so that we can take action.**

## Product Installation

### 1. Assembly and Disassembly

- A. This product has a pressure explosion-proof structure and is delivered fully assembled at the time of shipment. It does not require separate assembly and disassembly work by the user. (On-site wiring work is required by the constructor.)
- B. On-site construction must be performed by a qualified person or professional electrical contractor approved by the seller.

### 2. Installation and Precautions

#### A. Installation Method

- Make sure the power is turned off.
- Use the CABLE coming out of the product's cable gland. Wiring with the power cable is done in a separate certified junction box.
- Other wiring occurrences are in accordance with KS C IEC 60079-14.
- Except for the necessary piping holes, the remaining holes are finished with PLUG.

#### B. Precautions

- When installing explosion-proof electrical equipment, a technician must first ensure that the following specifications are met. This involves verifying their alignment with the provided terms."

Rated voltage and current rated frequency	Explosion level
Protection level of Container	Temperature Grade
Connecting Method & Type	Cable Entry Location
Surrounding Environment	Screw Dimensions
Types of explosion-proof Structures	Lead-in Type

- The installation location of electrical equipment in an explosion-proof area must take into account the following matters.
  - It should be installed in a location that is convenient for operation, maintenance, and adjustment.
  - It must be installed in a location where maintenance is easy and the space necessary for inspection or maintenance must be secured.
  - If possible, select a location that is not exposed to moisture, and avoid installing in a place that is always humid.
  - If possible, avoid installation near corrosive gas discharge ports or in locations where corrosive liquids scatter.
  - Avoid installing it in a location where it can be affected by significant vibration from machine and other equipment.

## Operational Maintenance

Please check the following thing regularly.

1. Terminal Voltage
2. Please check the ratings and types of each replaceable parts.
3. Please check regularly for e any abnormality in the operation of the entire control system, including control, operation, display, and notification.
4. Please check the presence and degree of vibration.
5. Inspect wiring inlet
  - A. Check the metal piping material that meets the standards for the conduit thread section
  - B. In order to ensure the explosion-proof performance of the electrical conduit, it is important to effectively install sealing. This involves verifying the proper installation of sealing, ensuring that the compound is filled to a sufficient depth, and confirming that the adhesion and hardening conditions are in good shape.
  - C. Check appropriate measures are taken to prevent rainwater from entering the screw joints of the electric machine.
6. Inspecting connections between wiring and electrical equipment
  - A. The circuit connection of the terminal symbol and polarity must be correct.
  - B. Ensure that the connection point is securely fastened, and measures are in place to prevent any loosening.
  - C. For connection points without terminals or similar components, ensure that effective insulation is in place.
7. Checking the container cover
  - A. There should be no damage or adhesion of foreign substances to the joint surfaces or threads of the lid, and non-hardening oil should be applied.
  - B. If packing is used for dustproofing or waterproofing, it must be installed properly.
  - C. The tightening screws must be free of defects and properly tightened.
8. The operational status will be in good condition based on the explosion-proof structure and operating conditions.

## Maintenance and Repairs

This product is continuously maintained through regular inspection as per Table 1 (recommended at least once a month).

Table 1 Electrical equipment inspection items for explosion-proof structure

Inspection Items	Method	Inspection Detail	Action Status
Container	Observation	No rust, damage and cracks found	Cleaning and Anti corrosion treatment
Joint surface	Observation	The surface must not be rough due to damage, rust,	Cleaning
Tightening Screw	Observation	No loosening, no adhesion of dust, no rust	Tightening Screw, Cleaning
Gap	Observation	No grease leakage and deterioration	Replacement
Inlet	Observation	No damage, deterioration or loosening	Tightening Screw Replacement
Connection	Observation	No loosening, no contamination on insulating material	Tightening Screws, Taping, Cleaning
Terminal Block	Observation	No loose connection in terminal.	Replace the damaged Screw
Packing	Observation	No breaks or Sagging	Replacement

When inspecting each electrical device with an explosion-proof structure, you must comply with the 'Do not open while energized' rule for the electrical device. After maintenance and before turning on the power, observe, inspect, assemble, and use the product in accordance with the inspection items in Table 1.

\* Other maintenance and repair matters follow as per KS C IEC60079-17 and KS C IEC60079-19.

## Caution

1. Do not open when explosive gas (dust) may present.
2. When performing inspection work while the power is on, the main body (cover) of the explosion-proof electric machine must not be opened.
3. When performing repairs in an explosion-proof area, be sure to avoid generating shock sparks from tools.
4. When performing maintenance and repairs, it is important to note that disassembly and assembly operations related to the explosion-proof performance of the explosion-proof electrical equipment are involved. Therefore, it is necessary to ensure that the explosion-proof performance is not compromised in other areas, not just the maintenance part
5. Maintenance and fault issues should be referred to the manufacturer if the user is unable to address or assess the issue.

## Manufacturer's Responsibility

The manufacturer demonstrates his responsibility for the following by marking the device in accordance with Clause 29 of KS C IEC 60079-0.

1. The device has been manufactured in compliance with the requirements of relevant standards regarding safety issues.
2. The routine verification and routine testing of KS C IEC 60079-0 28.1 have been successfully completed and the product complies with the document.

## Information about dimensions

Please contact the manufacturer for general requirements according to KS C IEC 60079-1 5.1.

## Warranty

1. The product warranty period is one year from the date of product sale.
2. This quality guarantee is only valid in Korea.
3. Be sure to read the user manual before using the product and use it according to the prescribed method.
4. We are not responsible for accidents or other occurrences caused by breakdown, damage, or careless handling by non-qualified workers.

## Paid service

1. Breakdown or damage due to user careless handling
2. Malfunction or damage caused by modification or repair by anyone other than the head office or handler.
3. Malfunction or damage due to abnormal power supply or defective connected devices.
4. Malfunction or damage caused by natural disasters (fire, salt damage, earthquake, wind and flood damage, lightning, etc.)
5. Other malfunctions and damage caused by outsourcing, not defects in the product itself.

## A/S (free service) and Inquiries

1. If a malfunction occurs during normal handling of this product, first check with the place of purchase for a diagnosis.
2. If the product breaks down under normal handling conditions, the place of purchase will provide free repairs during the warranty period.
3. If the repair service is not processed quickly or you have any inconveniences, please call our customer service center (see phone number on the first page) and we will notify you of the result as soon as possible.

## User's Disclaimer

Please be familiar with the contents of the user manual before using the product. We do not take any responsibility if you use it arbitrarily or adjust it.

## Safety Certification

This product has obtained safety certification from the Mandatory Safety Certification Notice for Safety Devices (Ministry of Employment and Labor Notice No. 2021-22).

## User Guide

User guide
This device has received a conformity assessment for use in a business environment, and may cause radio wave interference if used in a home environment.

**TOXIC & O<sub>2</sub> Gas List**

Gas Name	Measurement Range
AsCl <sub>3</sub>	0~10.0 PPM
AsF <sub>3</sub>	0~10.0 PPM
Ash <sub>3</sub>	0~1.00 PPM
BF <sub>3</sub>	0~10.0 PPM
B <sub>2</sub> H <sub>6</sub>	0~1.00 PPM
Br <sub>2</sub>	0~5.00 PPM
CH <sub>2</sub> O	0~10.0 PPM
C <sub>2</sub> H <sub>4</sub>	0~10.0 PPM
C <sub>3</sub> Cl <sub>3</sub> N <sub>3</sub>	0~10.0 PPM
C <sub>3</sub> F <sub>3</sub> N <sub>3</sub>	0~10.0 PPM
C <sub>4</sub> H <sub>4</sub> S	0~100 PPM
C <sub>4</sub> H <sub>9</sub> SH	0~10.0 PPM
Cl <sub>2</sub>	0~10.0 PPM
ClF <sub>3</sub>	0~ 10.0 PPM
ClO <sub>2</sub>	0~10.0 PPM
CO	0~100 PPM
COF <sub>2</sub>	0~10.0 PPM
GeCl <sub>4</sub>	0~10.0 PPM
F <sub>2</sub>	0~1.00 PPM
H <sub>2</sub>	0~1000 PPM
HBr	0~10.0 PPM
HCl	0~10.0 PPM
HCN	0~50.0 PPM
HF	0~10.0 PPM
H <sub>2</sub> S	0~100 PPM
I <sub>2</sub>	0~10.0 PPM
NH <sub>3</sub>	0~100 PPM
N <sub>2</sub> H <sub>4</sub>	0~1.00 PPM
NO	0~100 PPM
NO <sub>2</sub>	0~20.0 PPM
O <sub>2</sub>	0~25 %VOL
O <sub>3</sub>	0~1.00 PPM
PCl <sub>3</sub>	0~10.0 PPM
PCl <sub>5</sub>	0~10.0 PPM
PH <sub>3</sub>	0~5.00 PPM
POCl <sub>3</sub>	0~10.0 PPM
S <sub>2</sub> F <sub>10</sub>	0~10.0 PPM
SbH <sub>3</sub>	0~1.0 PPM
SeH <sub>2</sub>	0~5.00 PPM
SiCl <sub>4</sub>	0~10.0 PPM
SiH <sub>4</sub>	0~50.0 PPM
SiH <sub>4</sub> Cl <sub>2</sub>	0~10.0 PPM
SO <sub>2</sub> F <sub>2</sub>	0~10.0 PPM
SnBr <sub>4</sub>	0~10.0 PPM
SiHCl <sub>3</sub>	0~10.0 PPM
TBM	0~50.0 mg/m <sup>3</sup>
TEOS	0~100 PPM
THT	0~100 mg/m <sup>3</sup>
TiCl <sub>4</sub>	0~10.0 PPM