

2-Color pyrometer

2IGA – 100

Temperature Range: 400~1200

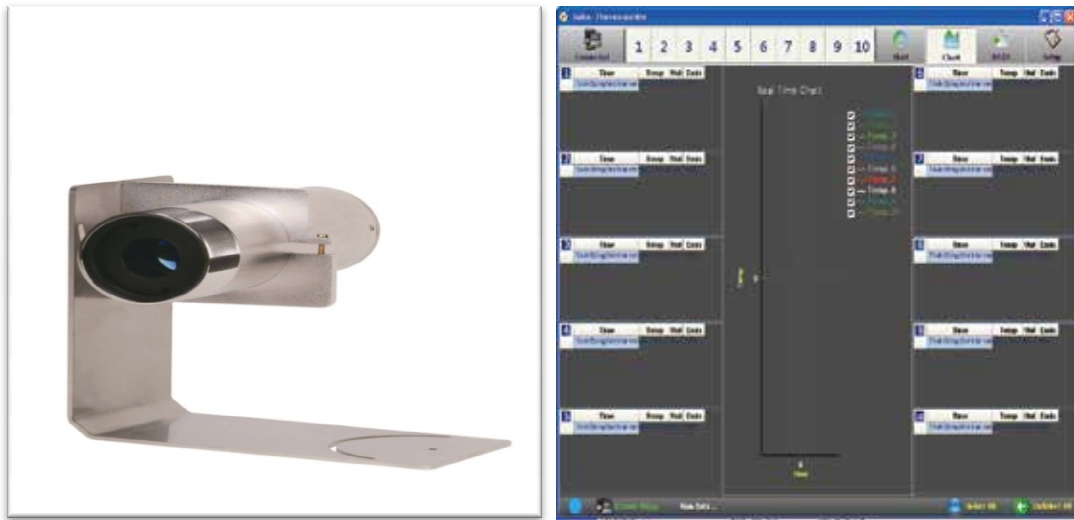

GASDNA Co.,Ltd 101, Bukhang-ro 193beon-gil, Seo-gu, Incheon, 22856, Republic of Korea
Tell: +82-32-584-7420 Fax: +82-32-584-7424 E-mail: sales@gasdna.com Web: www.gasdna.com

<http://www.gasdna.com>

1. Features

2IGA-100 non-contact pyrometer is adapting two-color sensor, which make it to measure target object accurately than One-color sensor under a emissivity change.

Two-color sensor is using two comparing sensors which have a different wavelength.

This sensor can measure target object accurately although it is partially obscured by an obstacle, or smoke in the air, dust, veiled by large dust particles. And it still can be measured accurately when sensor lens is piled up with foreign substances

2IGA-100 non-contact pyrometer measures the infrared wavelength emitted from the target and converts it to standard current signal output (4~20mA) or RS-485 communication signal output, it still provides relay contact for alarm signal.

It can measure from 400 °C to maximum 1200°C and user can change a temperature range, it has a high accuracy by adapting optical lens. 2IGA-100 can measure a target in long distance through 80:1 D:S (Distance to Spot).

Emissivity is 0.75 ~ 1.25 adjustable in two-color mode. Two built-in laser pointers can aim at the target.

2. Ordering information

Code Number 2IGA-100-□-□-□

MODEL	Description
Code A	Temperature Range
1	300~ 700 °C
2	400~ 1200 °C
Z	Other
Code B	Output
M	DC 0~20mA
N	DC 4~20mA
V	DC 1~5V
Z	Other
Code C	Cable Length
1	3m Cable
Z	Other

3. Accessories

Description	Shape	Usage	Remark
Fixing nut		Sensor fixing nut	Basic accessory

4. Product specification

Segment	2IGA-100
Range	400~1200 ℃
Accuracy	2℃ or ±1%
Repeatability	±1% of reading
Distance : Spot (D:S)	80:1
Wavelength Range	0.8~1.1 μm
Sensor Type	Two color (InGaAs/InGaAs)
Response Time	Within 0.1 sec
Emissivity (one color)	0.10~0.99
Emissivity (two color)	0.75~1.25
Analog Output	4~20mA, 1~5V(option)
Communication output	RS-485
Relay output	1 step- Relay Contact (High/Low)
Power	DC 12~24V(Max 200mA)
Ambient temperature	0~70℃
Temperature Resolution	1℃
Operating Relative Humidity	5~90%
Storage Temperature	-30~85℃
Waterproof	IP65,NEMA 4
Laser point	630~670nm(red)
Housing material	SUS
Weight	960 g
Cable length	3m,other

5. Optical Field of View (D:S= 80:1)

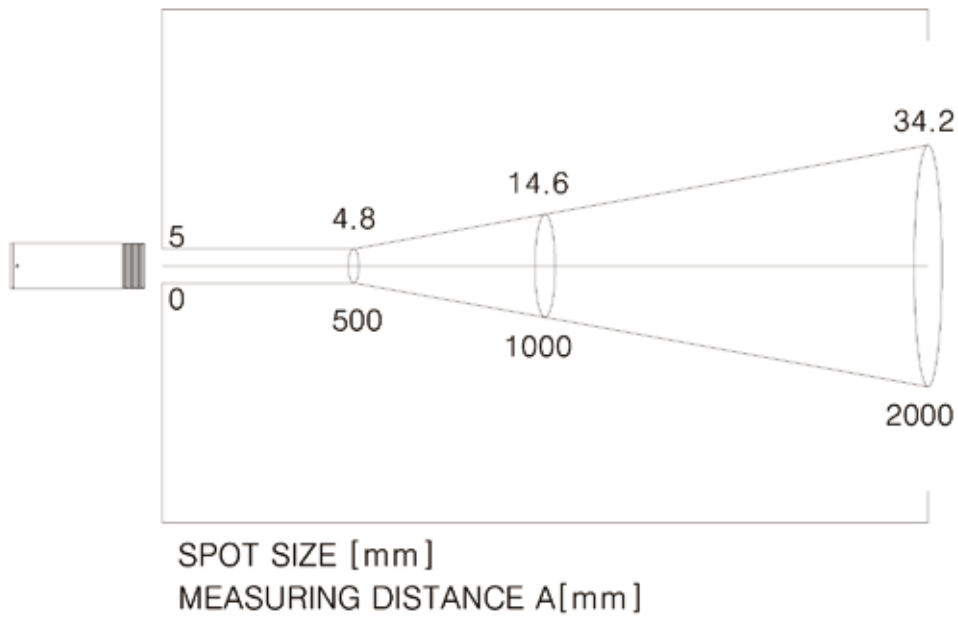

6. Laser pointer adjustment



To aim a target object, enter the switch.
Please press ENT switch for laser pointer on/off.

7. Product description

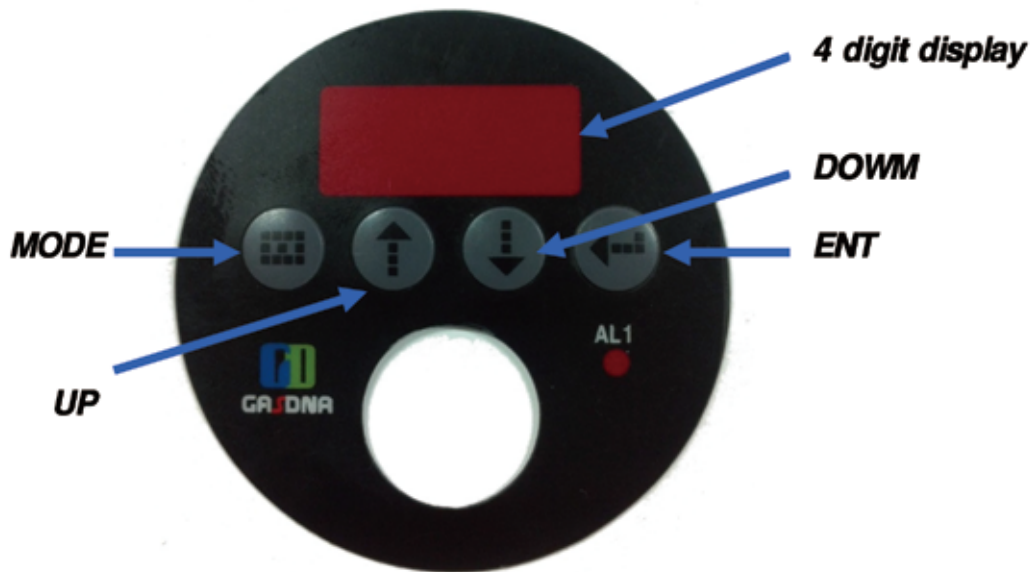

Name	Description
MODE	<ul style="list-style-type: none"> - Enter into Set-up Mode. - Move to other menu on setting menu
UP	Increase the value of measuring range by 1 unit. ※ When you keep touching it during 5 sec, the value increases fast.
DOWN	Decrease the value of measuring range by 1 unit. ※ When you keep touching it during 5 sec, the value decreases fast.
UP+DOWN	Press UP & DOWN at the same time when want to enter measuring mode from setting menu
ENT	Store the set value.

8. Wiring

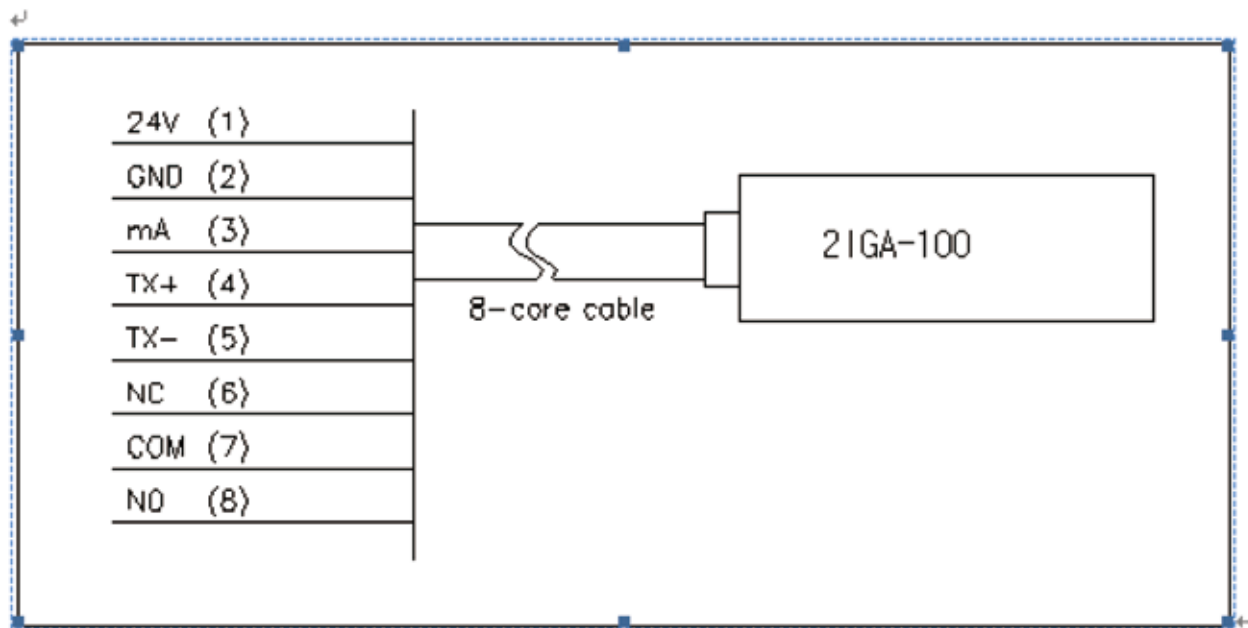

No.	Wire color	Usage
1	Black	Power 24VDC(+)
2	Brown	Power 0V(-)
3	Red	Analog output(+)
4	Orange	RS485 A
5	Green	RS 485 B
6	Blue	Relay Normal close
6	Purple	Relay Common
7	Grey	Relay Normal open

9. Menu (PARAMETERIZING)

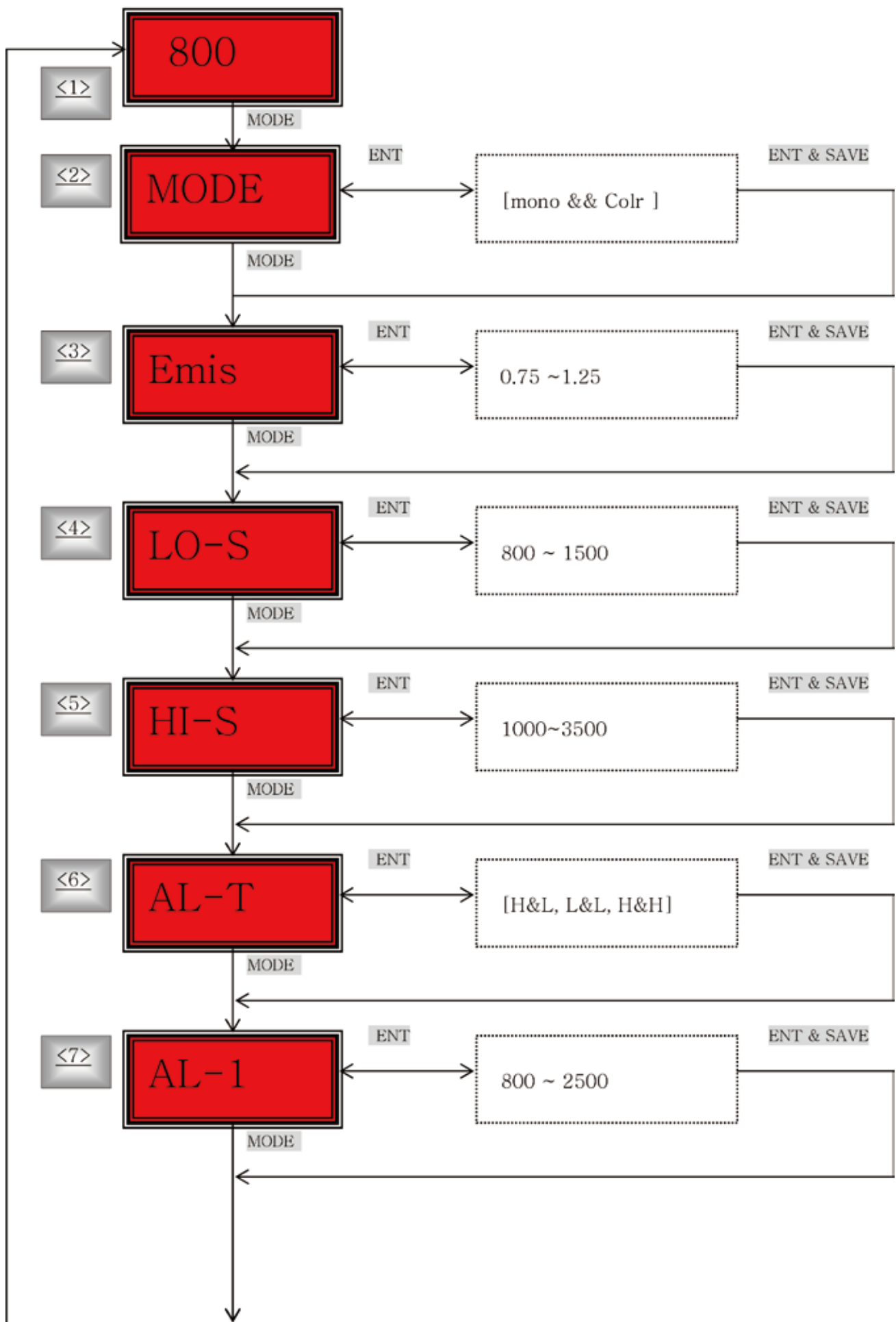

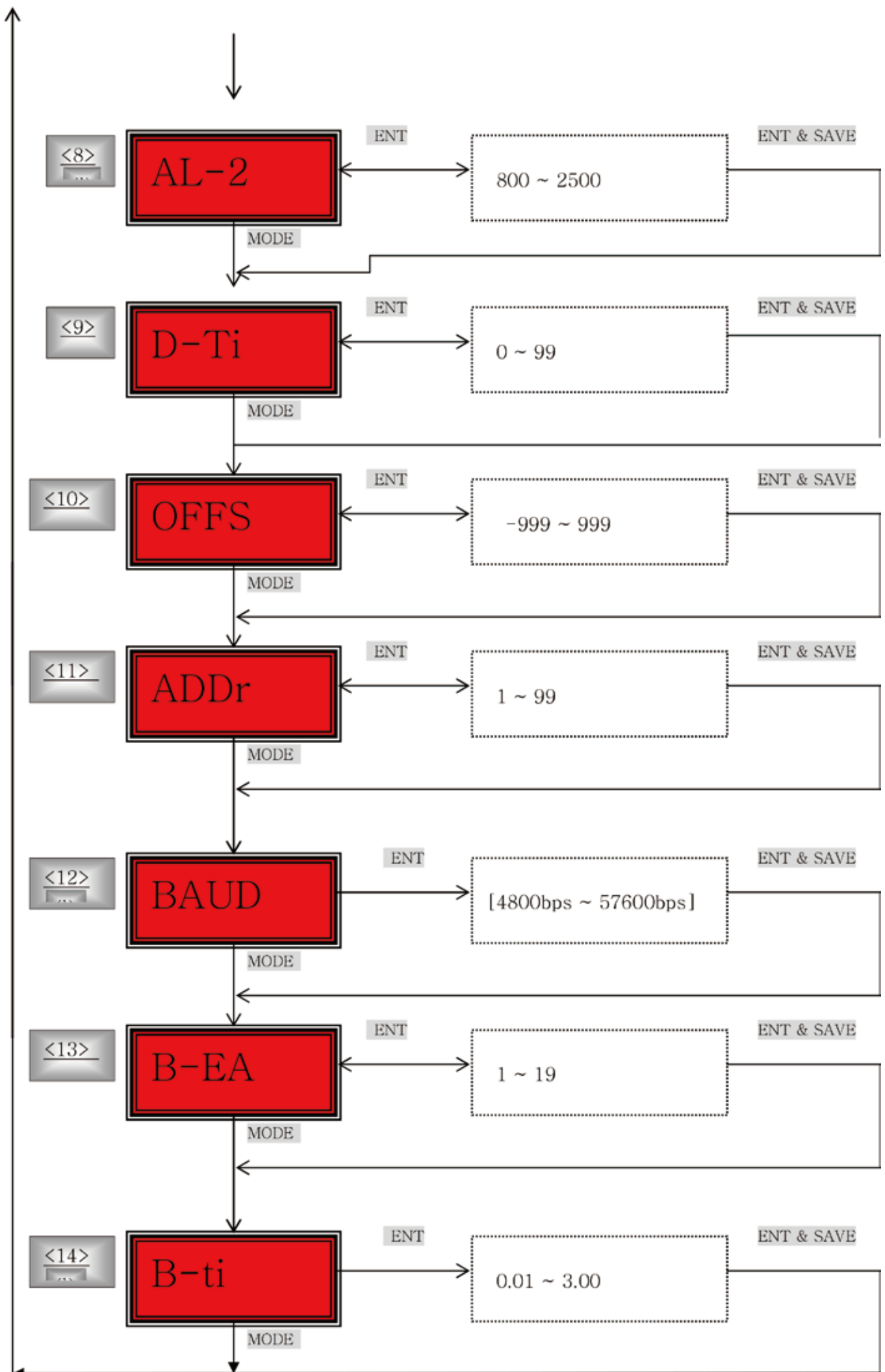

<1> Measuring Mode

- Display a measuring temperature by 4 DIGIT
- Enter the setting mode when press **MODE** 2 seconds

<2> MODE

- Select 1-color or 2-color

<3> Emission

- Adjust emissivity of target

<4> LO-SCALE

- 4mA setting for FULL SCALE

<5> HI-SCALE

- 20mA setting for FULL SCALE
- (ex) If you set HI-SCALE as 2000:

4mA Analogue Output -----	<input type="text" value="Lo"/>	Display.
12mA Analogue Output -----	<input type="text" value="1400"/>	Display.
20mA Analogue Output -----	<input type="text" value="1000"/>	Display

<6> AL-TYPE (ALARM-TYPE)

- Three(3) types of alarm settings (H-L, L-L, H-H)
- ALARM Relay can use two - ALARM-1,ALARM-2

6-1> H&L Setting

- ALARM-1: ALARM-1 (If more than set value, relay on)
- ALARM-2: ALARM-2 (If less than set value, relay on)

6-2> L-L Setting

- ALARM-1: ALARM-1(If less than set value, relay on)
- ALARM-2: Ignoring

6-3> H-H Setting

- ALARM-1: ALARM-1(If less than set value, relay on)
- ALARM-2: Ignoring

<7> ALARM-1

- ALARM-1 Alarm relay output (Please refer to 'ALARM TYPE' setting)

<8> ALARM-2

- ALARM-2 Alarm relay output (Please refer to 'ALARM TYPE' setting)

<9> AL-TIME(ALARM TIME)

- This menu is to prevent abrupt malfunction affected by shock or noise from outside.

<10> OFFSET (Compensate measured value)

- compensate the error of measured value which happened by sensor.

ex) OFFSET: If you set -5:

- When the sensor output error is +5, display shows 0 after it compensates -5.

<11> ADDRESS

- RS-485

<12> BAUDRATE

- RS-485

<13> B-EA (sampling buffer number, use when measuring high temperature)

- user use it in the range of 1~19
- calculate average value as much as buffer number
- ex) Temperature average = (500+502+504+506)/4=503

4 samples	500	502	504	506
-----------	-----	-----	-----	-----

<14> B_TIME (Sampling delay time. Use when measuring high temperature)

- user use it in the range of 0.00 ~ 3.00 sec

ex)

- 0.00 sec setting → sampling of temperature value every 1 msec .
- 0.01 sec setting → sampling of temperature value every 10 msec .
- 1.00 sec setting → sampling of temperature value every 1000 msec

10. Communication specification and software

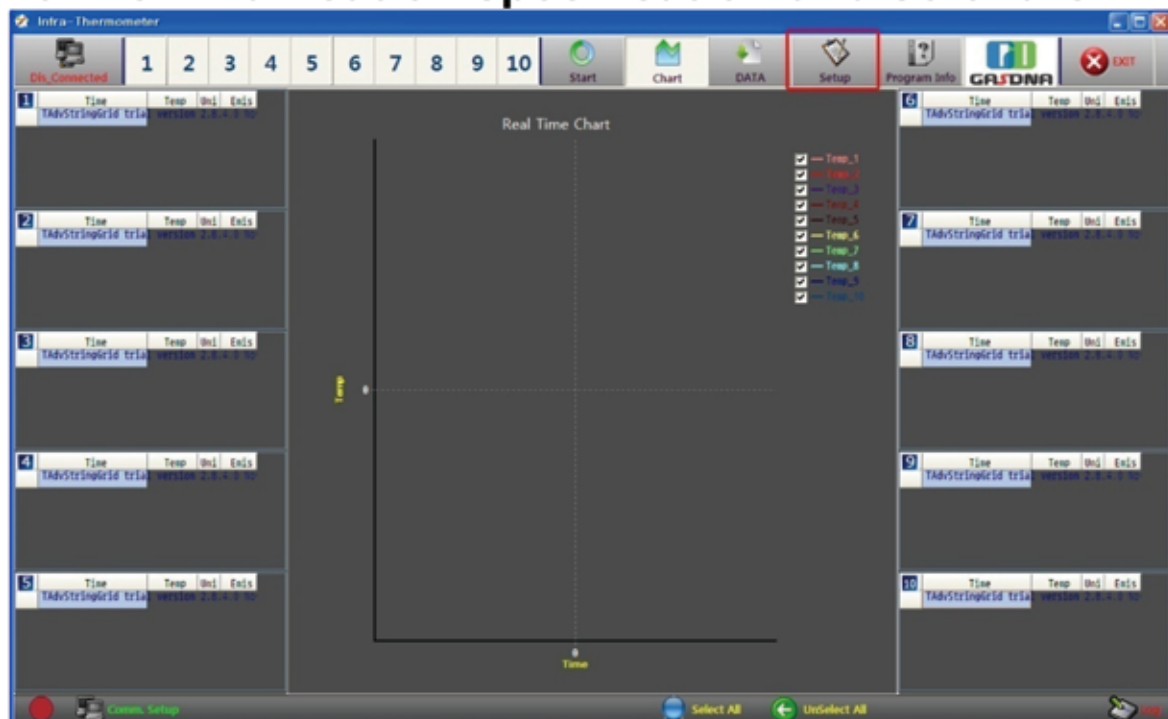

Serial Interface((Initial value setting))

Baud Rate: 9600 baud

Data bits: 8

Parity: none

Stop bits: 1

***Please refer to software menu additionally.**

11. Option

Air-purge

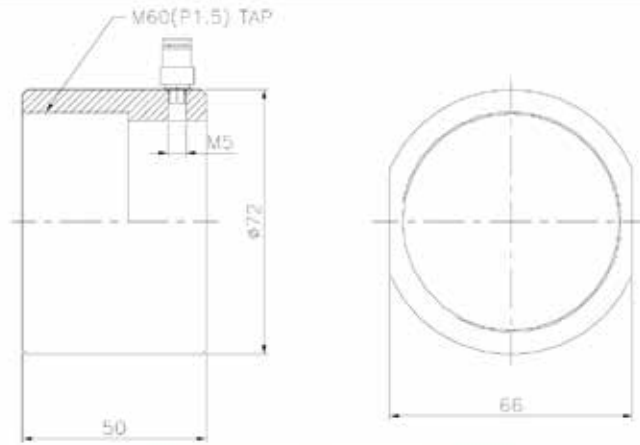

Air cooler

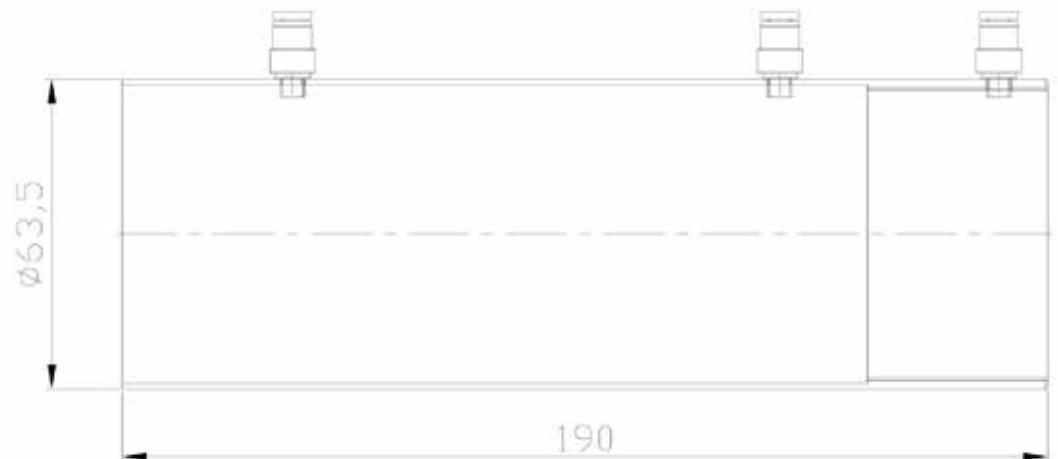

Up and down adjustable Bracket

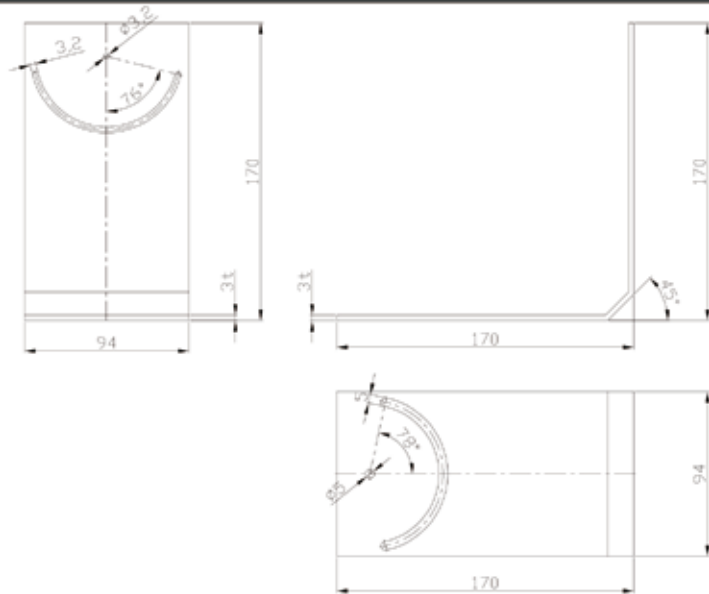

485 To RS232 Converter



Indicator (DI-20)



2 Inch Led Display



12. INSTALLATION

□ Please make sure the target area is larger than the field of view.

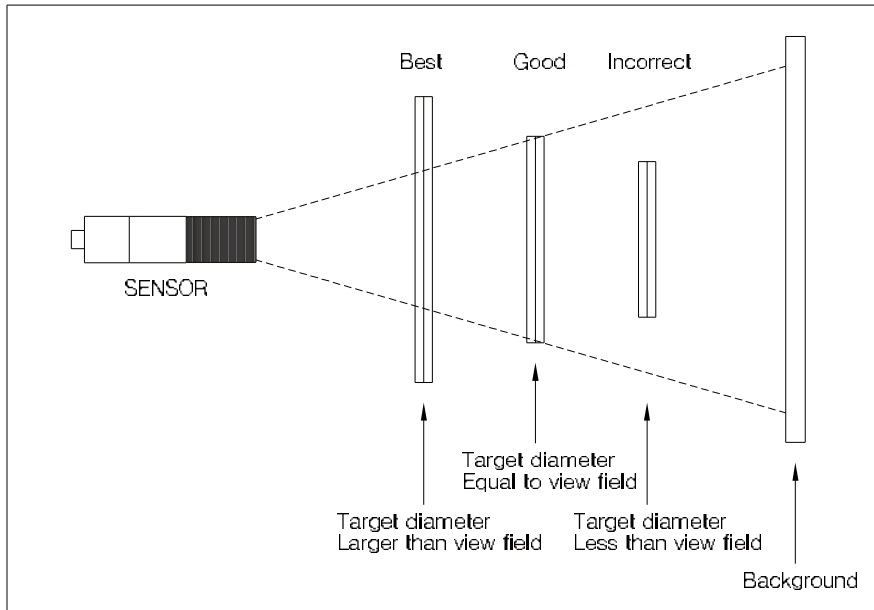

The spot size is decided by the distance from the sensor to the target.
Please refer to the 'section 5. Optical field of view' and make sure your target area is larger than the field of view.



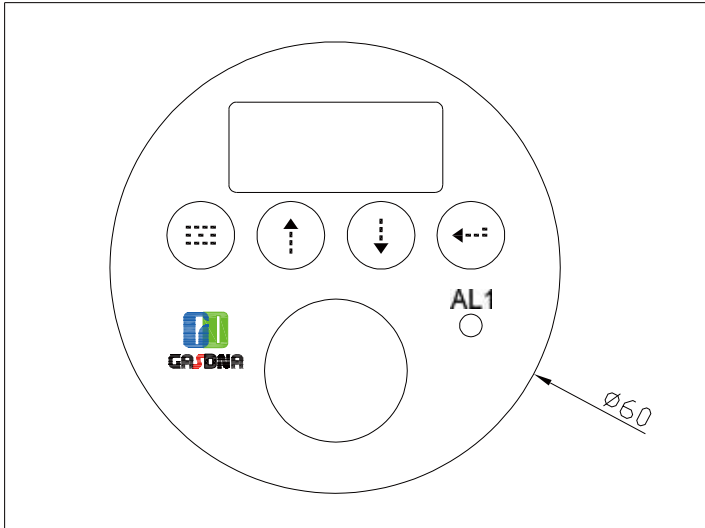

● **Bracket**

