

# Non-Contact Infrared Temperature

## IR - 22

### Sensor / Transmitter

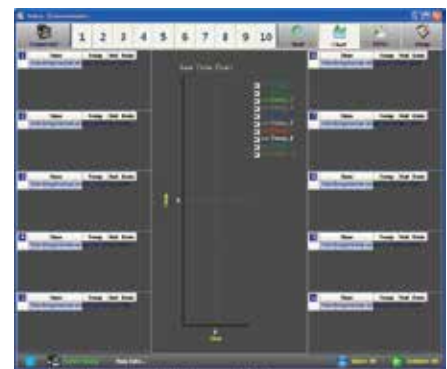

**GASDNA Co.,Ltd** 101, Bukhang-ro 193beon-gil, Seo-gu, Incheon, 22856, Republic of Korea  
Tell: +82-32-584-7420 Fax: +82-32-584-7424 E-mail: sales@gasdna.com Web: www.gasdna.com

<http://www.gasdna.com>

## 1. Features

IR-22 non-contact infrared thermometer measures the infrared wavelength emitted from the target spot and converts it to standard current signal output (4~20mA) and RS-485 communication signal output.

It can measure from -60°C to maximum 380°C and RS-485 communication enables to store data in computer.

IR-22 has a high precision by adopting optical lens which can enable to measure target exactly at a long distance through its 10:1 D:S (Distance to Spot).

### • Applications



Plastics, Fluids, Rubber, Coated components, Asphalt, Wood, Paper, Ceramics, Textiles, Glass, Food etc.

## 2. Ordering information

Code Number IR-22-□-□-□

MODEL	Description
IR-22	
Code A	Temperature Range
1	-60~380°C
2	0~200°C
Z	Other
Code B	Output
M	DC 0~20mA
N	DC 4~20mA
Z	Other
Code C	Cable Length
1	1M
Z	Other (OPTION)

### 3. Accessory

Name	Picture	Usage	Remark
Fixing nut		Sensor fixing nut	Basic accessory
Mounting bracket		Sensor mounting bracket	Basic accessory

### 4. Specification

Segment	Specification
Measurement Range	-60~380℃
Device	Thermopile
Accuracy	±1% / full scale
Repeatability	±1% of reading
Field of View (D:S)	10:1
Optical spectrum wave	8~14μm
Responsive Time	0.1sec or below
Emissive rate	0.95fixed ((Changeable when using PC software program))
Analog Output	4~20mA,
Communication output signal	RS-485
Power	DC 12~24V(Max 50mA)
Ambient temperature	-20~70℃
Temperature Resolution	0.1℃
Operating Relative Humidity	5~90%
Storage temperature	-30~85℃
Dimension	Ø16 × 70.5(L)
Casing material	SUS
Weight	75g
Cable length	1m, other(option)

## 5. Optical Field of View (D:S 10:1)

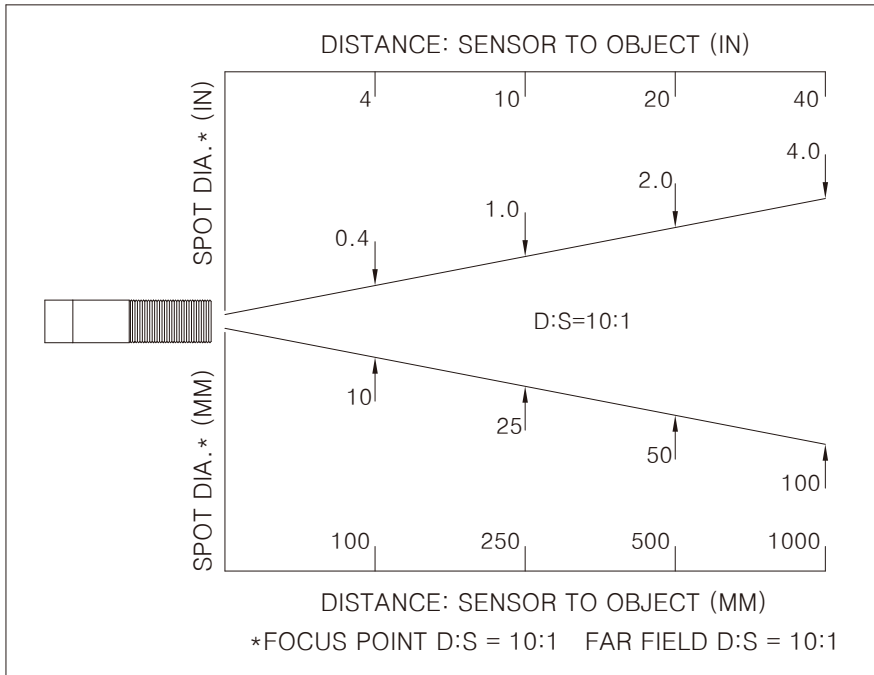

## 6. Dimension

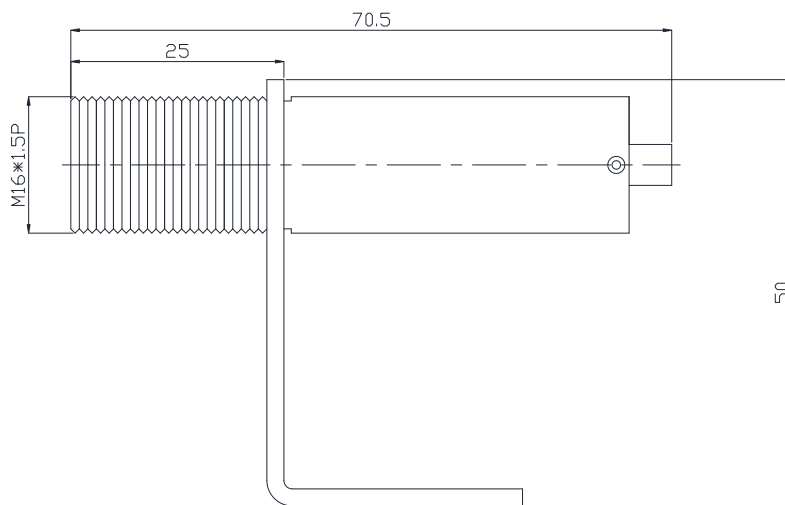

## 7. Wiring

No.	Cable color	Usage
1	Black	Power 24VDC(+)
2	Red	Power 0V(-)
3	Yellow	mA (Current) Analog output
4	Green	TX+
5	White	TX-

## 8. Communication specification and Software

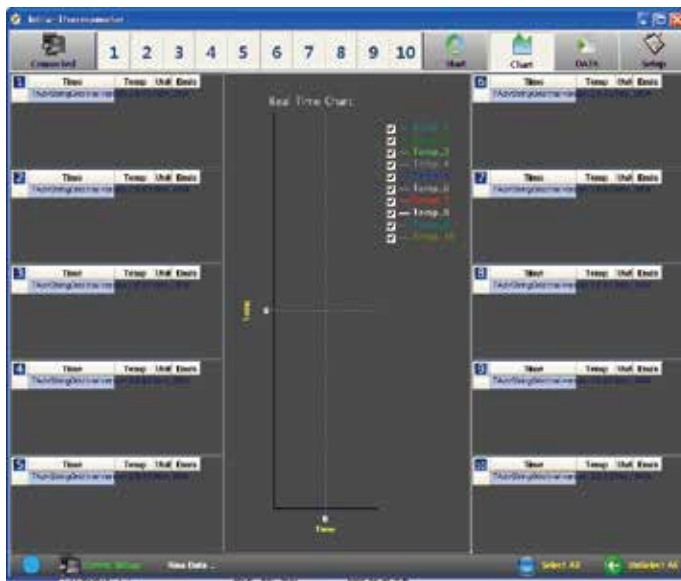

## 9. Emissivity Table

Material	Emissivity
Black body	0.95
Asphalt	0.90~0.98
Textiles, Fabric	0.98
Concrete	0.94
Ascon	0.95
Skin	0.98
Leather	0.75
Sand	0.90
Soil	0.92~0.96
Paint	0.8~0.95
Water	0.92~0.96
Ice	0.96~0.98
Rubber	0.94
Snow	0.83
Plastic	0.85~0.95
Wood	0.90
Ceramic	0.90~0.94
Glass	0.90~0.94
Marble	0.94
Chromic Oxide	0.78
Iron Oxide	0.78~0.82
Brick	0.93~0.96
Copper oxide	0.78
Mortar	0.89~0.91

## 10. Installation

- Please make sure the target area is larger than the field of view.

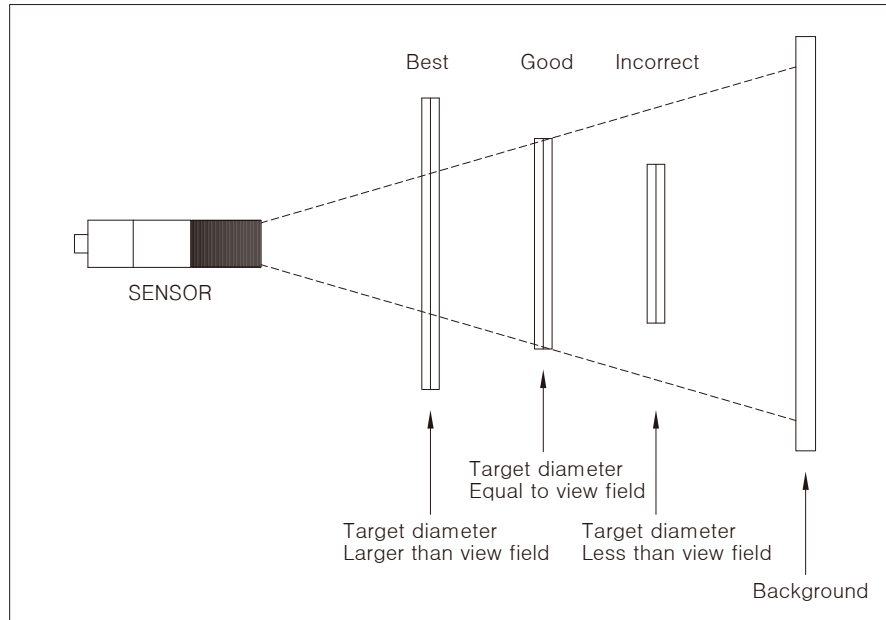

- The spot size is decided by the distance from the sensor to the target.
- Please refer to the 'section 5. Optical field of view' and make sure your target area is larger than the field of view.

- Please locate the sensor vertical against the target.

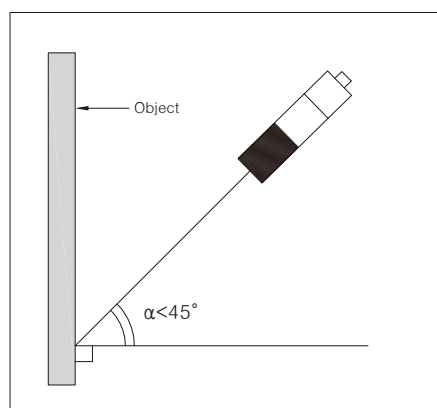

- It is the best for you to install the sensor vertical against the target area or object. If it is not available, the sensor should be more than 45° against the target area. Otherwise, it can affect the measuring accuracy.

- Please avoid the heat reflection from other high temperature materials

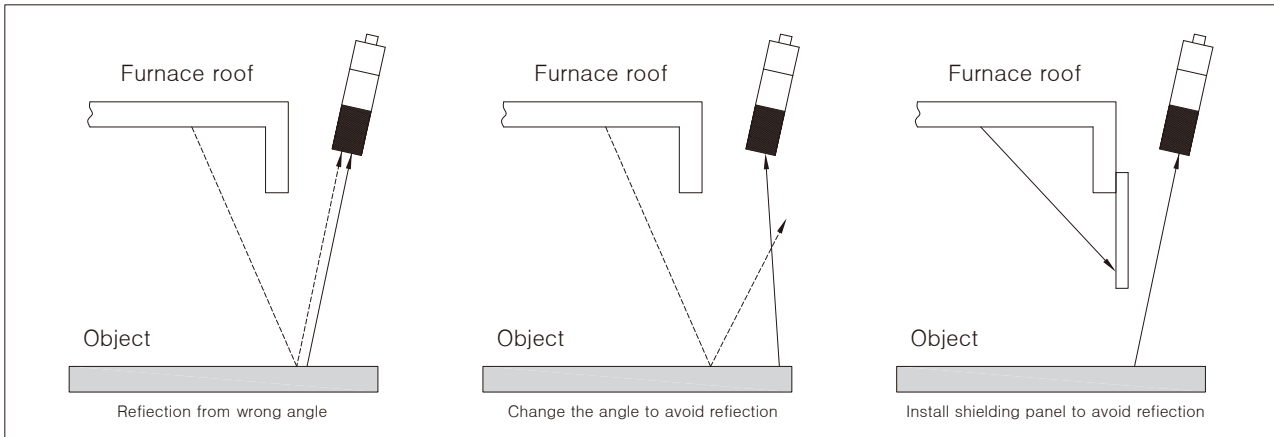

- Please avoid highlight.

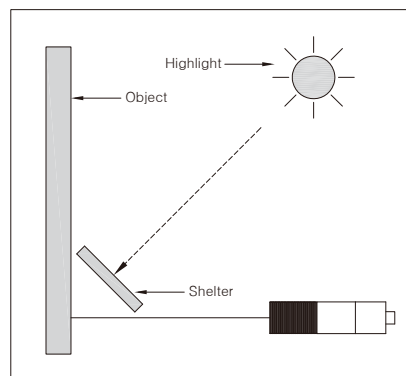

- Please avoid electronic noise.

Please avoid the high frequency or high voltage area such as motor, pump, power line, and so on.