

# Fixed Infrared Thermometer

# Brazing-3.9

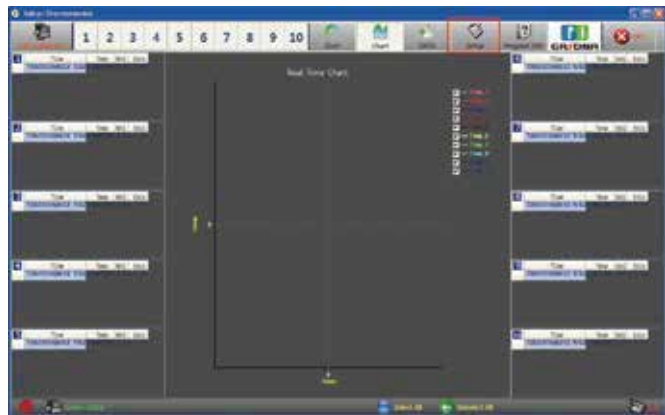

**GASDNA Co.,Ltd** 393-17 Wonchang-dong, Seo-gu, Incheon, Republic of Korea

Tell: +82-32-623-7507

Fax: +82-32-623-7510

E-mail: sales@gasdna.com

Web: www.gasdna.com

<http://www.gasdna.com>

## 1. Features

Brazing 3.9 infrared thermometer measures the infrared wavelength emitted from the target spot and converts it to standard current signal output (4~20mA) and RS-485 communication signal output.

- Measuring temperature 300~1300℃
- Actual measuring location and size can be measured in some distance, By using double laser system.
- It gets through fire(flame) and measures the targets temperature.
- Makes maximum effectiveness in process of brazing
- It can measure the inside wall of a high temperature furnace.
- Show maximum transmissivity in clean and high temperature gas or flame, Also can measure inner part under glass surface.
- Able to use without a cooling device up to 85℃ of Ambient temperature And when the temperature becomes 50℃, It has automatic laser shut off function.

### ● Applications



Brazing, Inside wall in furnace, heating furnace, inside of glass, kiln, incinerator etc.

## 2. Ordering information

Code Number Brazing-3.9-□-□-□

MODEL	Description
Brazing- 3.9	
Code A	Temperature Range
1	300~1300℃
2	300~1600℃
Z	Other
Code B	OutPut
N	4~20mA
Z	Other
Code C	Cable Length
1	3m Cable
Z	Other

### 3. Accessory

Name	Picture	Usage	Remark
Fixing nut		Sensor fixing nut	Basic accessory
Mounting bracket		Sensor mounting bracket	Basic accessory

### 4. Specification

Segment	Speification
Range	300~1300℃
Accuracy	±1%/F.S
Repeatability	±1% of Observed Value
Field of View(D:S)	60:1
Wave Length	3.9μm
Response Time	less than 10msec
Emissivity	0.10~1.00
Analog Output	4~20mA
Communication output	RS-485
Relay Output	2 step- Relay Contact (AL1/AL2)
Input Power	DC 20~24V(Max 200mA)
Ambient Temperature Compensation	0~80℃
Resolution	1℃
Relative Humidity	5~90%
Storage Temperature	-30~85℃
Waterproof	IP65,NEMA 4
Laser Pointer	630~670nm(red)
Size	Body Control: 98 × 64 Sensing Head: 27× Ø10
External Material	SUS
Weight	650 g
Cable Length	3m,other

**5. Dimension**

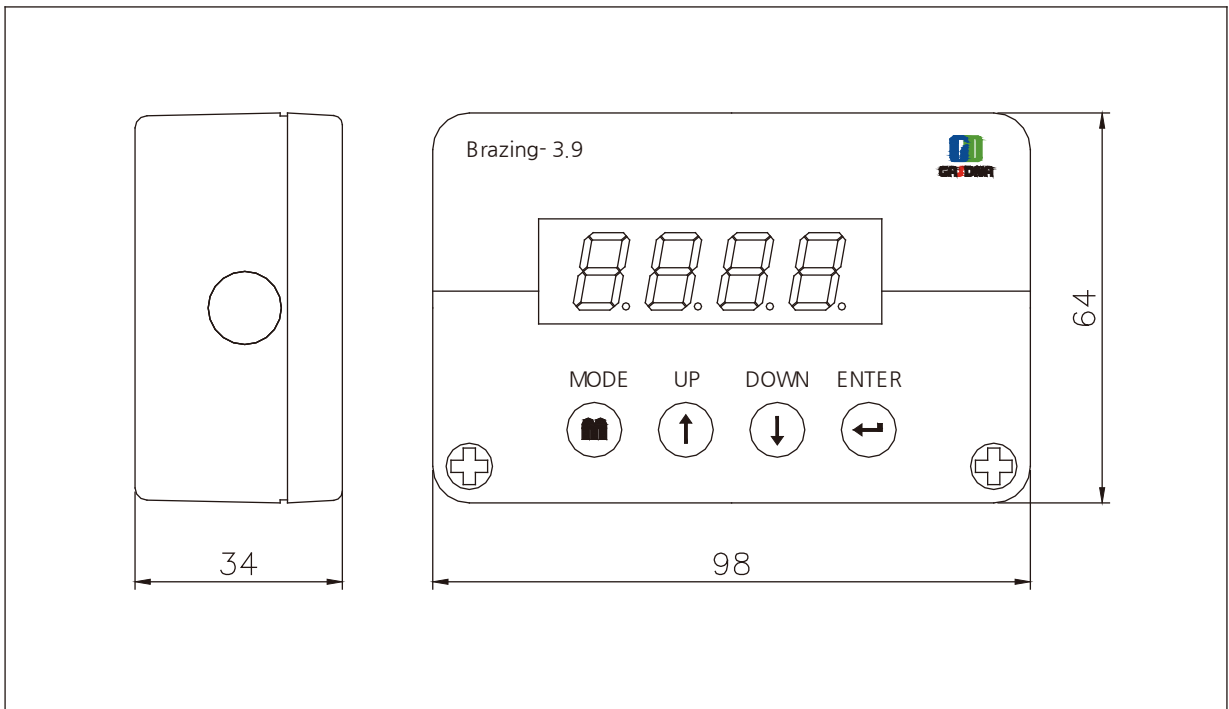
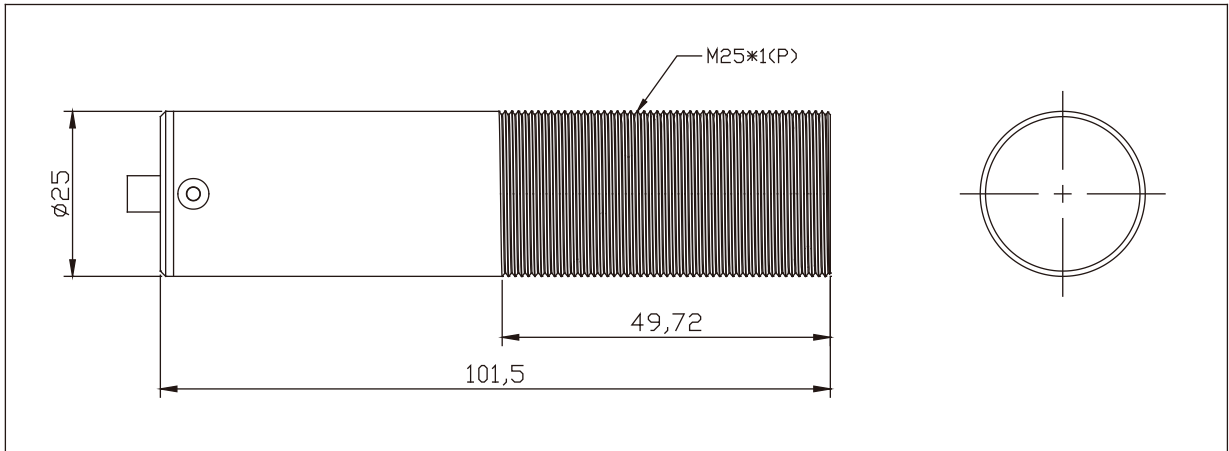

## 6. Electrical Connection

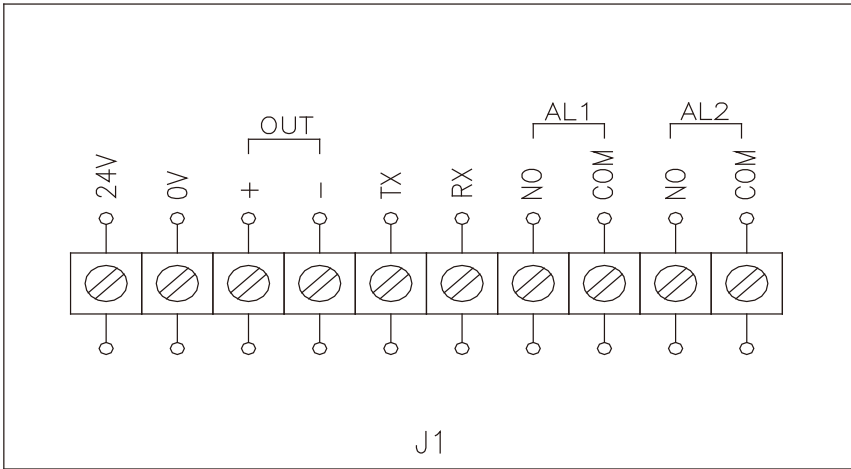

No.	Printed Name	Usage
1	24V	Power 24VDC(+)
2	0V	Power 0V(-)
3	Out +	4-20mA Analogue Signal Output(+)
4	Out -	4-20mA Analogue Signal Output(-)
5	TX	RS485 TX+
6	RX	RS485 TX-
7	AL1 [NO/COM]	ALARM1 RELAY CONTACT
8		
9	AL2 [NO/COM]	ALARM2 RELAY CONTACT
10		

## 7. Optical field of view (DS 60:1)

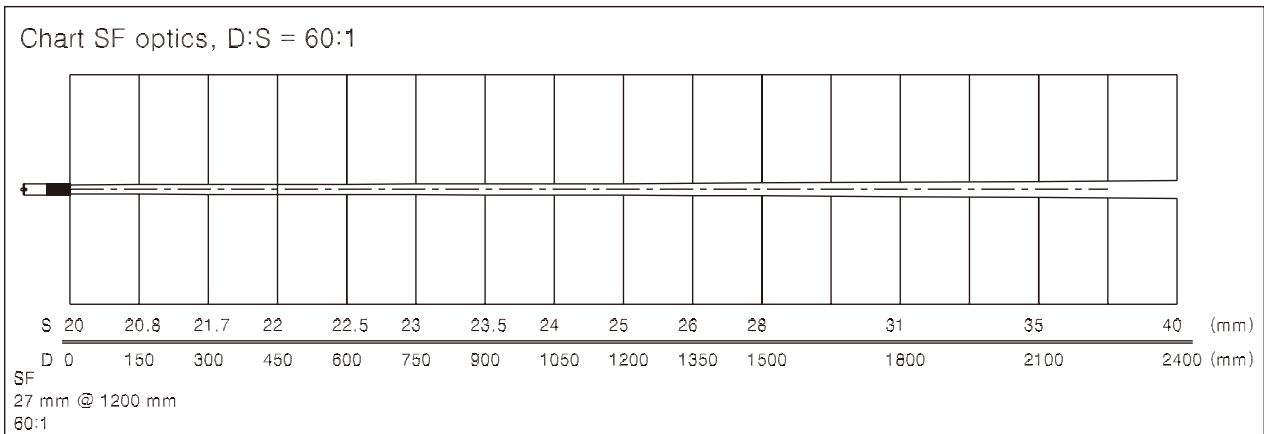

## LCD DISPLAY & KEYPAD

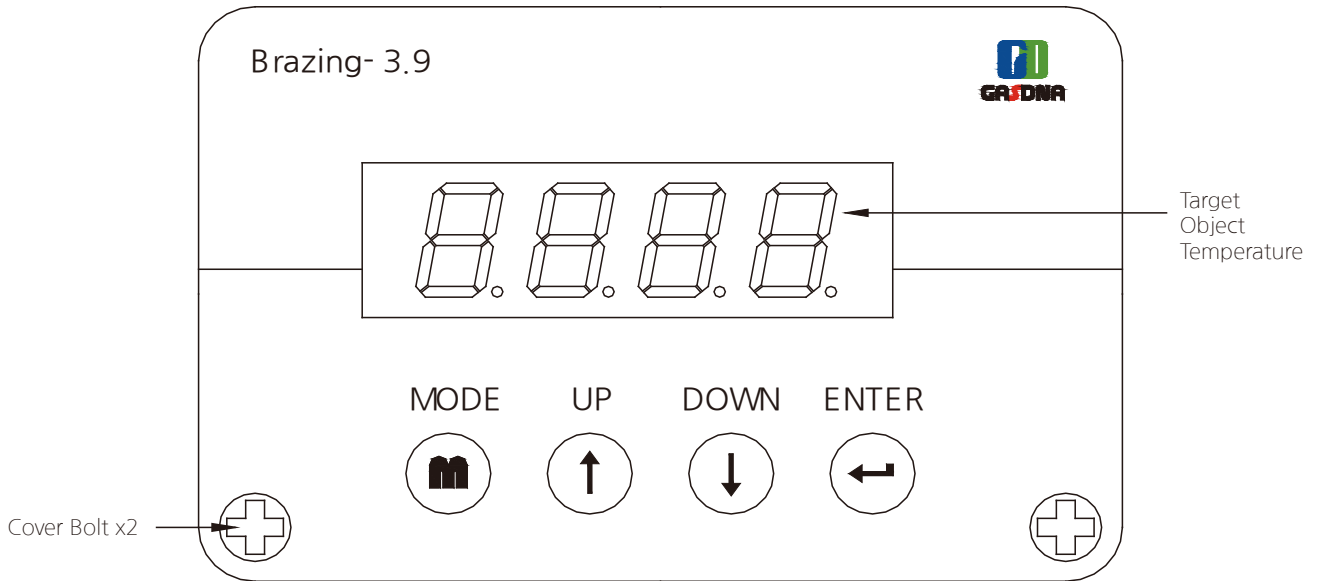

Label	Function
<b>MODE</b>	- Enter into Set-up Mode. - In Set-up Mode, move the setting area.
<b>UP</b>	Increase the value of measuring range by 1 unit. ※ When you keep touching it during 5 sec, the value increases fast.
<b>DOWN</b>	Decrease the value of measuring range by 1 unit. ※ When you keep touching it during 5 sec, the value decreases fast.
<b>ENT</b>	Store the set value.
<b>UP+DOWN</b>	- Enter into Set-up Mode. - In Set-up mode, Used when entering measure mode.

**9. Menu (Parameterizing)**

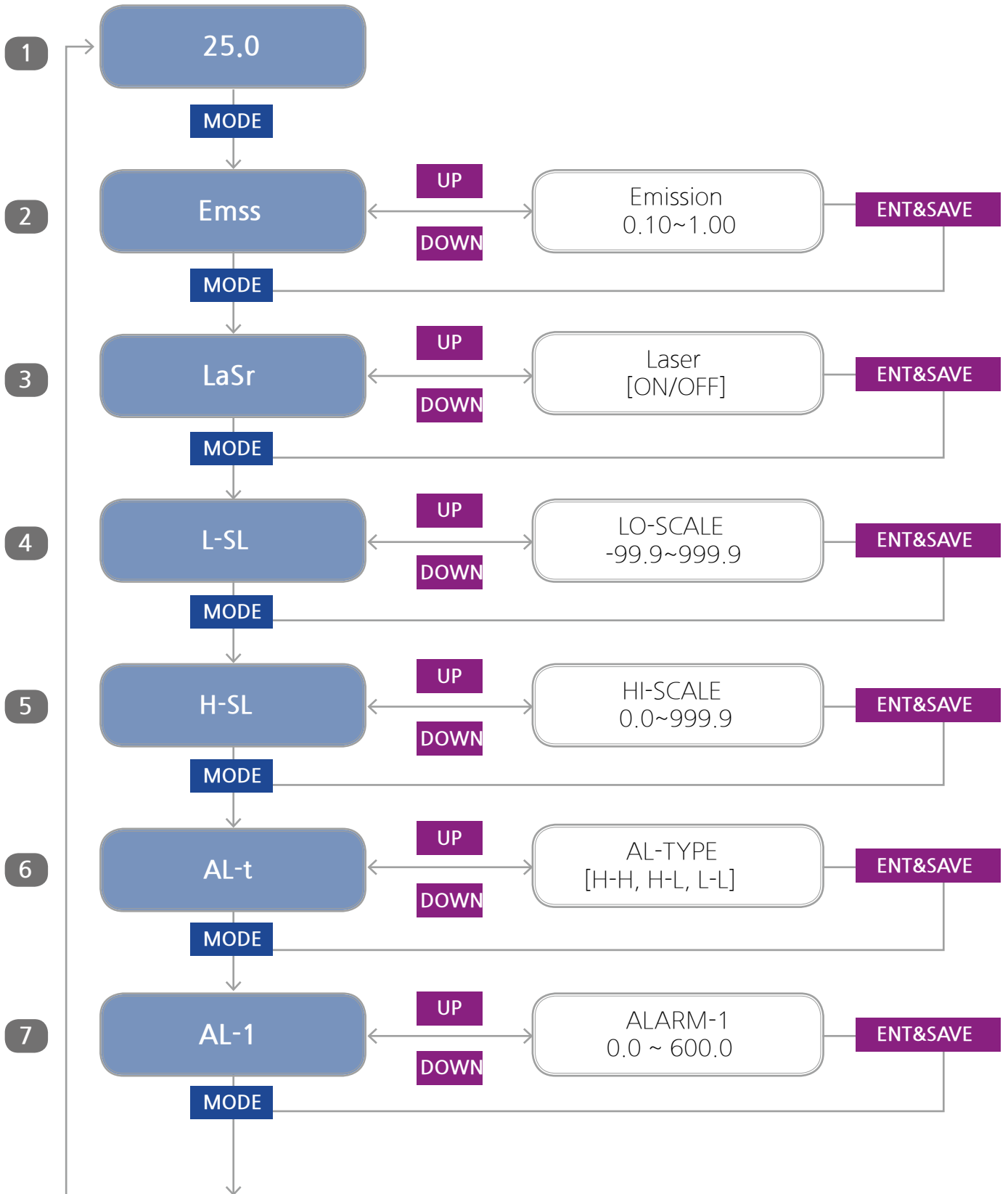

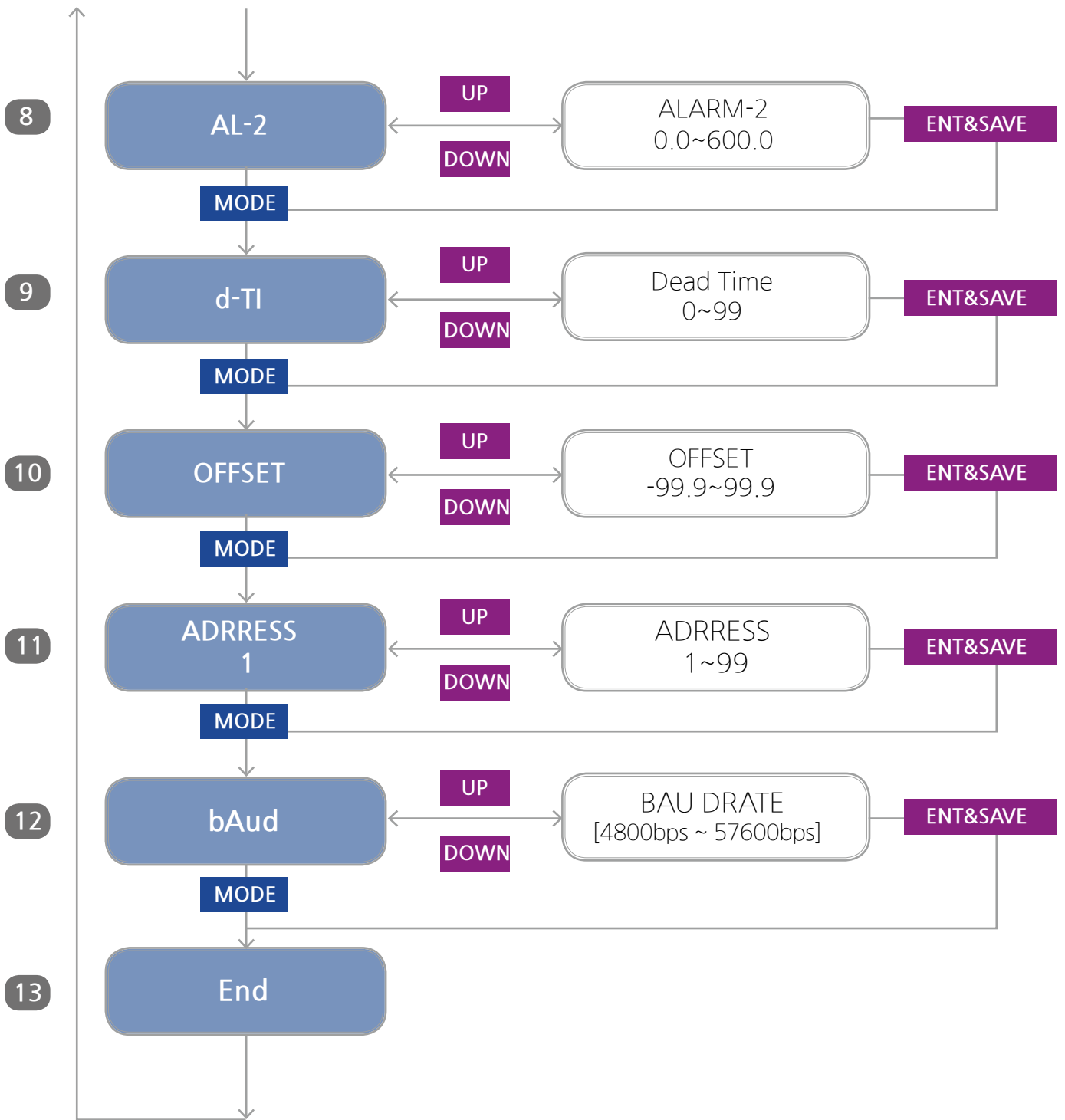



**1 Mode**

- Measure the temperature of object and display it on LCD in real time.
- When you push **MODE** during 2 seconds, you can enter into Set-up Mode.

**2 Emission**

- Manual to adjust objects emissivity(After adjusting emissivity, You need to turn input power on/off)

**3 Laser**

- Operate Laser Pointer to aim at object.

**4 LO-S CALE**

- 4mA for FULL SCALE

**5 HI-S CALE**

- 20mA for FULL SCALE

(ex) If you set HI-SCALE as 100:

4mA Analogue Output -----	0.0	Display
12mA Analogue Output -----	50.0	Display
20mA Analogue Output -----	100.0	Display

**6 AL- TYPE(A LARM- TYPE)**

- 3 types of alarm settings(H-H, H-L, L-L)
- two(2) alarm relays(ALARM-1, A LARM-2)

ex) If you set H&L:

- A LARM-1: HIGH A LARM(If more than set value, relay on)
- A LARM-2: LOW ALARM(If less than set value, relay on)

**7 ALARM-1**

- ALARM-1 alarm relay output(a ccording to A LARM TYPE, LOW & HIGH alarm occurs)

**8 ALARM-2**

- ALARM-2 alarm relay output(a ccording to A LARM TYPE, LOW & HIGH alarm occurs)

**9 AL-TIME(A LARM TIME)**

- This menu is to prevent abrupt malfunction affected by shock or noise from outside.

**10 OFFS ET(Compensate measured value)**

- compensate the error of measured value which happened by sensor.

ex) OFFSET: If you set -5:

- When the sensor output error is +5, display shows 0 after it compensates -5.

**11 ADDRESS**

- RS-485 address set

**12 BAUDRATE**

- RS-485 address set

**13 End**

**10. Communication specification and Software**

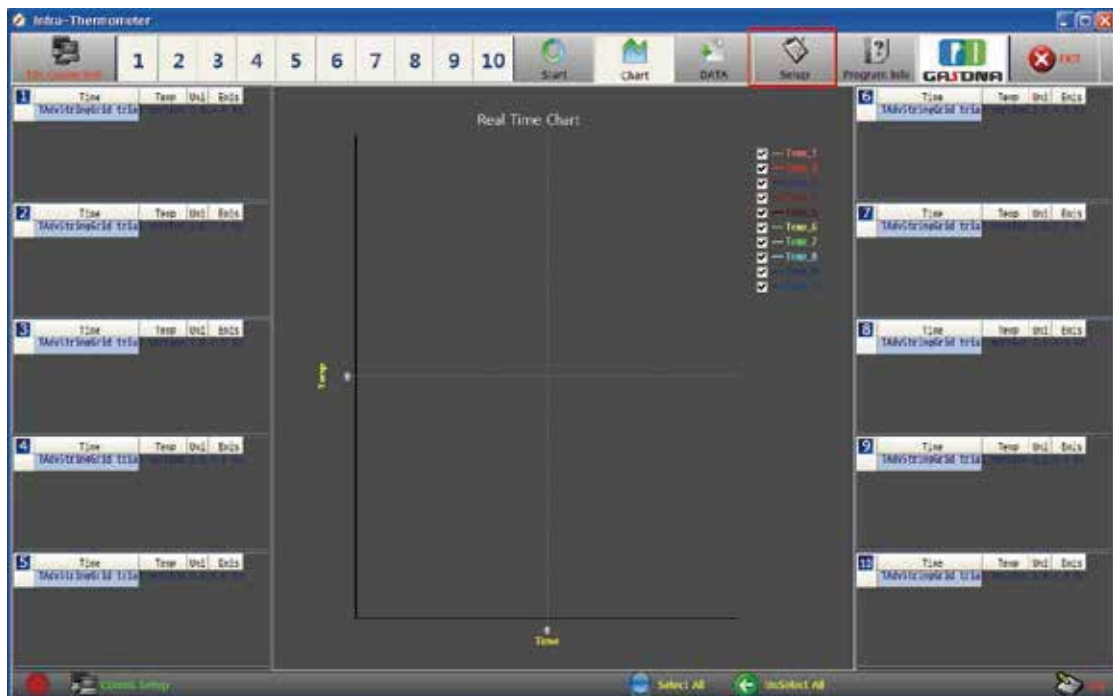

**11. Option**

		
Up and Down adjustable Bracket	Laser Pointer	Indicator(DI-20)