

Non-Contact Infrared Temperature Sensor/Transmitter

Temperature Range: 500~1700 °C

IR – 80 - H

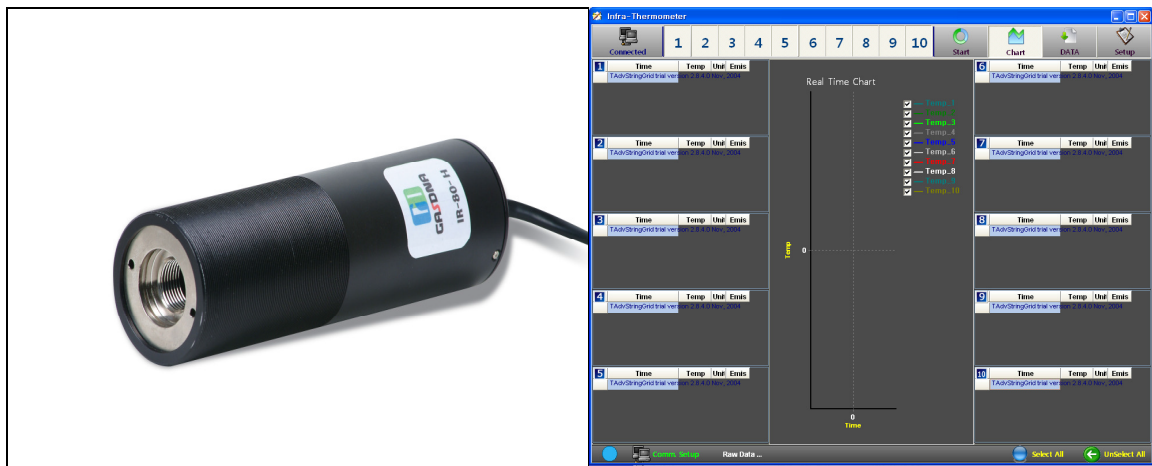

Best Detectors, Best Service



GASDNA co.,ltd 393-17 Wonchang-dong, Seo-gu, Incheon, Republic of Korea

Tell: +82-32-623-7507

Fax: +82-32-623-7510

E-mail: sales@gasdna.com

Web: www.gasdna.com

<http://www.gasdna.com>

1. FEATURES

IR-80 non-contact infrared thermometer measures the infrared wavelength emitted from the target and converts it to standard current signal output (4~20mA) and RS-485 communication signal output.

It can measure from 500 °C to maximum 1700 °C in the distance of 80:1 D:S (Distance to Spot). Emissivity is 0.10 ~ 0.99 adjustable. Two built-in laser pointers can aim at the target.

※ **Applications:**



Aluminum, Chrome, Copper, Metal, Magnesium, Oxide-nickel, Platinum, Gold, Silver, Oxided-Titanium, Zinc, Tin, Steel, Oxided- Steel, Oxided-Brass

2. Ordering information

Code Number IR-80-H-□-□-□

MODEL	Description
IR-80-H	
Code A	Temperature Range
1	500~1500 °C
2	500~1700 °C
Z	Other
Code B	OutPut
M	0~20mA
N	4~20mA
V	Voltage Output(DC 1~5V)
Code C	Cable Length
1	3m Cable
Z	Other

3. Accessories

Description	Shape	Usage	Remark
Fixing nut		Sensor fixing nut	Basic accessory
Mounting bracket		Sensor mounting bracket	Basic accessory

4. SPECIFICATIONS

Segment	Specification
Temperature Range	500~1700 °C
Device	InGaAs
Accuracy	±1%/F.S
Repeatability	±1% of reading
Field of View(D:S)	80:1
Optical spectrum wave	1~1.6 μ m
Responsive Time	100msec or below
Emissivity rate	0.1~0.99
Analog Output	4~20mA, 1~5V(option)
Communication output signal	RS-485 communication signal
Power	DC 12~24V(Max 50mA)
Ambient temperature	0~70 °C
Temperature Resolution	0.1 °C
Operating Relative Humidity	5~90%
Storing Ambient Temperature	-30~85 °C
Waterproof	IP65,NEMA 4
Laser pointer	630~670nm(red)
Dimensions	51 ×171(L)
Weight	600g
Casing material	Aluminum Alloy
Cable length	3m,other

5. OPTICAL FIELD OF VIEW (D:S = 80:1)

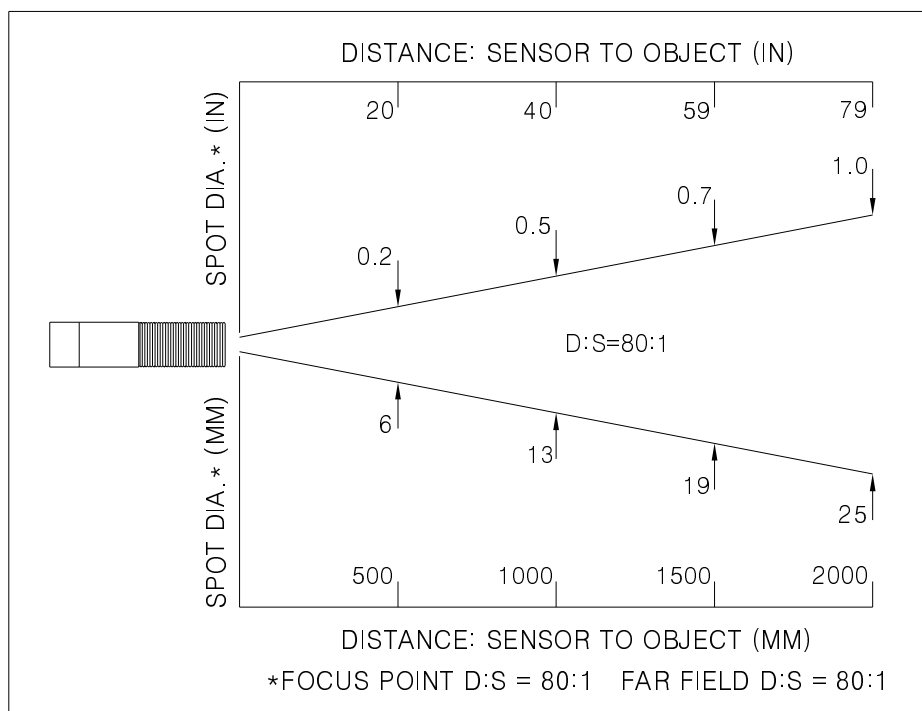

6. Emissivity adjustment and Laser on/off



[Emissivity Adjustment]

Please rotate the emissivity adjust dial on the back side of sensor to change the emissivity.

[Laser on/off]

To aim object, Please activate laser pointer.
Please press laser switch for laser pointers on/off.
Laser will be turned off automatically after 5 minutes.

7. IR-80-H OUTSIDE DIMENSION

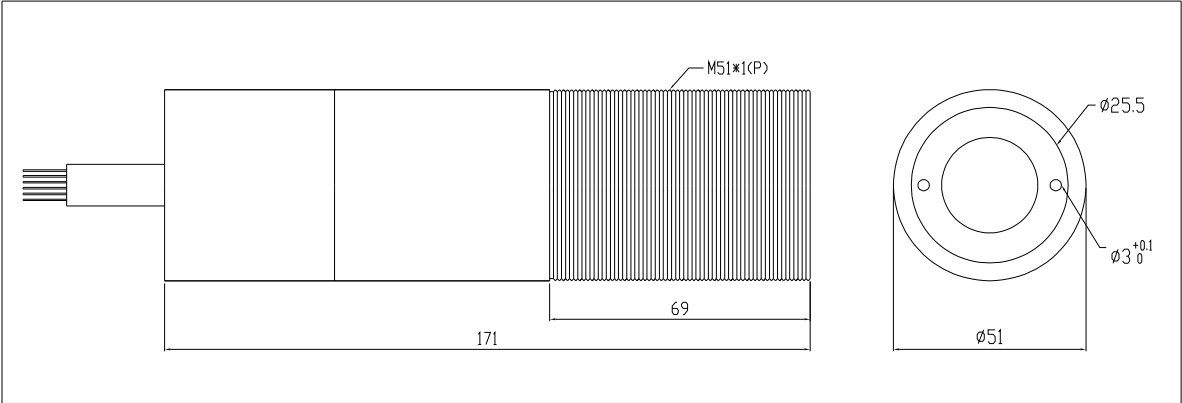

8. Wiring

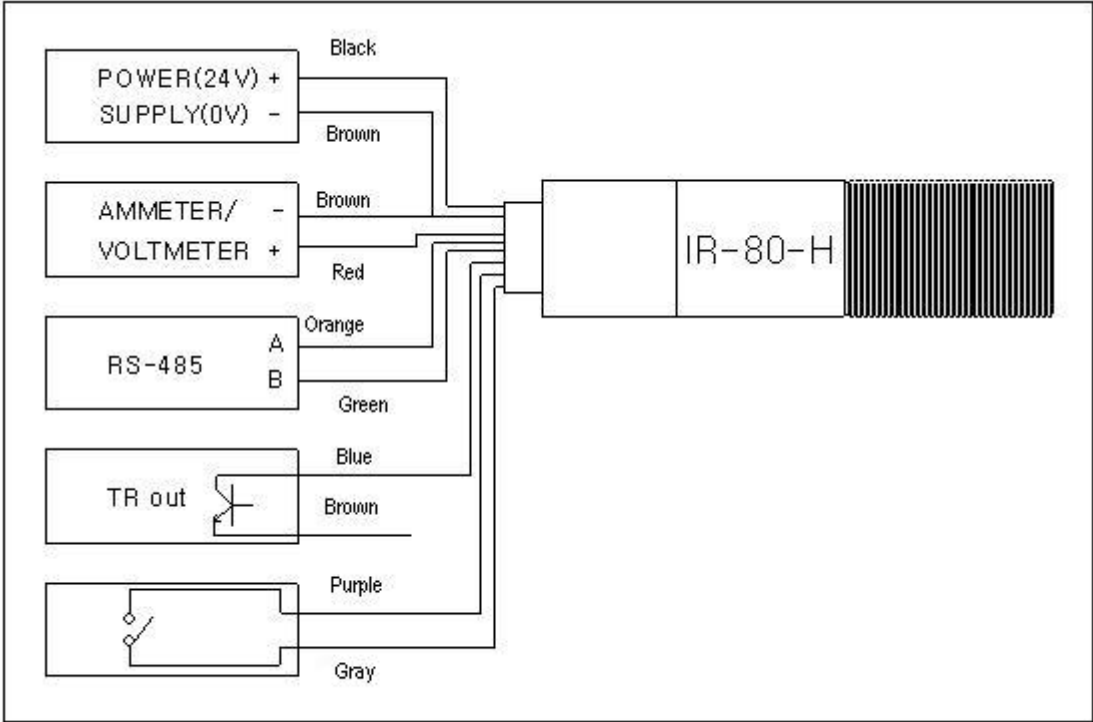

No.	Wire color	Usage
1	Black	Power 24VDC(+)
2	Brown	Power 0V(-)
3	Red	Analog output(+)
4	Orange	RS485 A
5	Green	RS 485 B
6	Blue	NPN Transistor Output
7	Purple	Relay NO
8	Gray	Relay com

9. Communication specification and Software

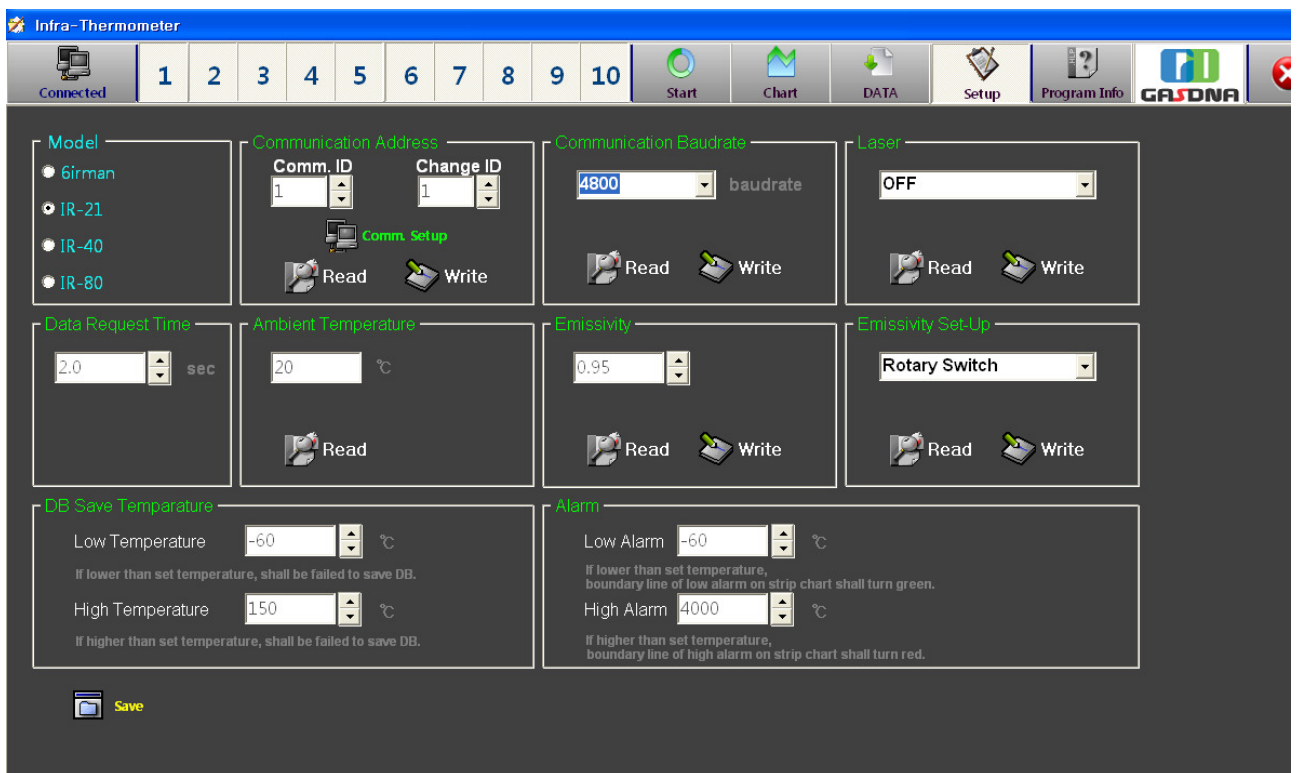
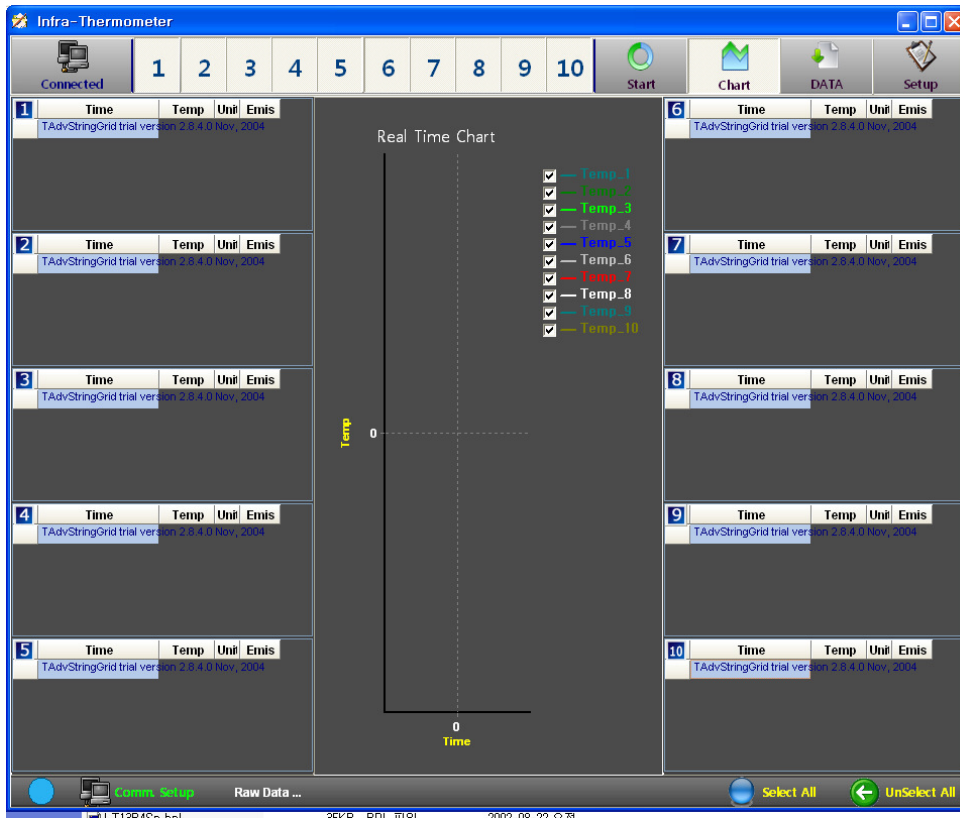

Serial Interface (Initial value setting)

- Baud Rate: 4800, 9600 setting
- Data Request time: data reading speed setting
- Ambient temperature: Ambient Temperature
- Emissivity: Emissivity setting
- DB Save Temperature: storage temperature setting

Alarm : setting when you want to see temperature transition in detail by graph within measured temperature range

EX> Set low alarm to 10°C (Green) and Set High Alarm to 30°C (Red) for No 1 Thermometer as below.

EX >

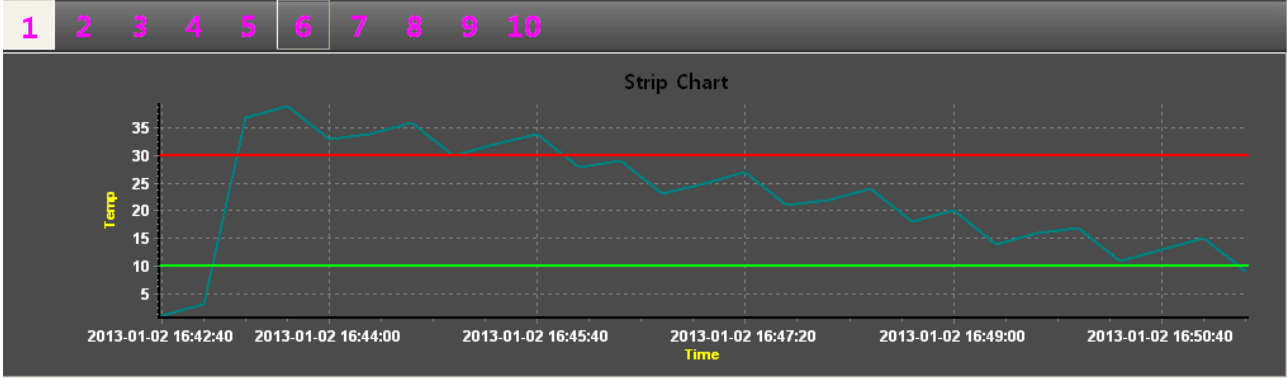

♣ Caution: After setting value, Please do not forget to press 'Save' button

10. OPTION

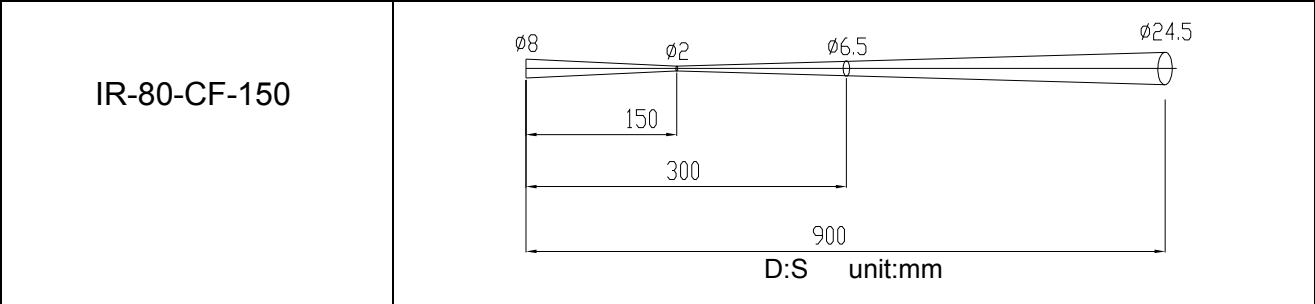

Air-purge

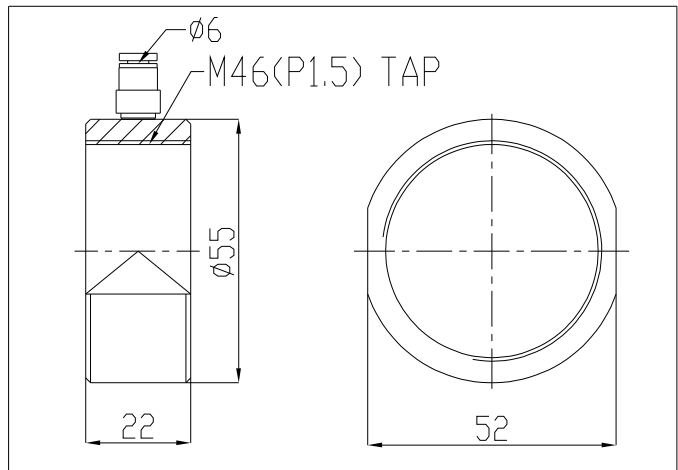

Air/Water Cooler

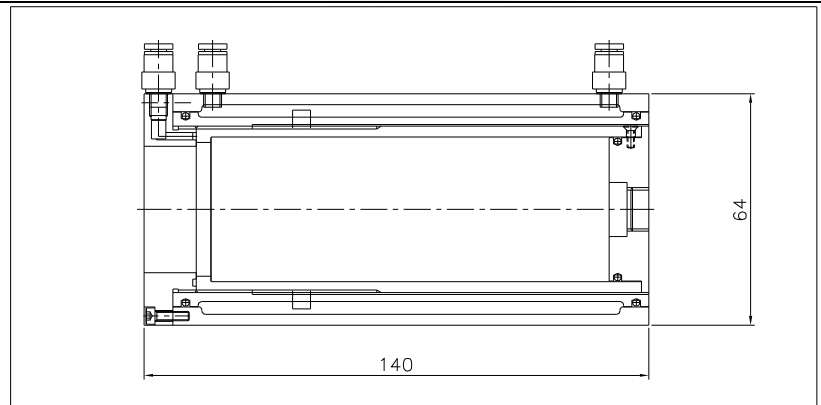

Up and down adjustable Bracket

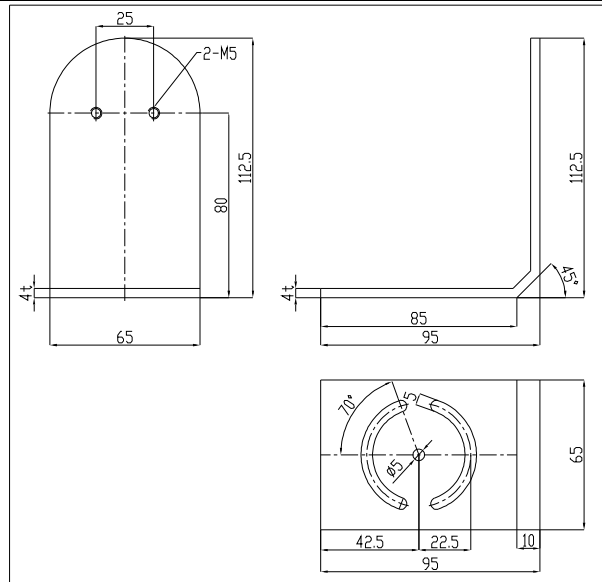

485 To RS232 converter



Indicator
(Model No. DI-20)



2 Inch LED Display



11. INSTALLATION

- Please make sure the target area is larger than the field of view.

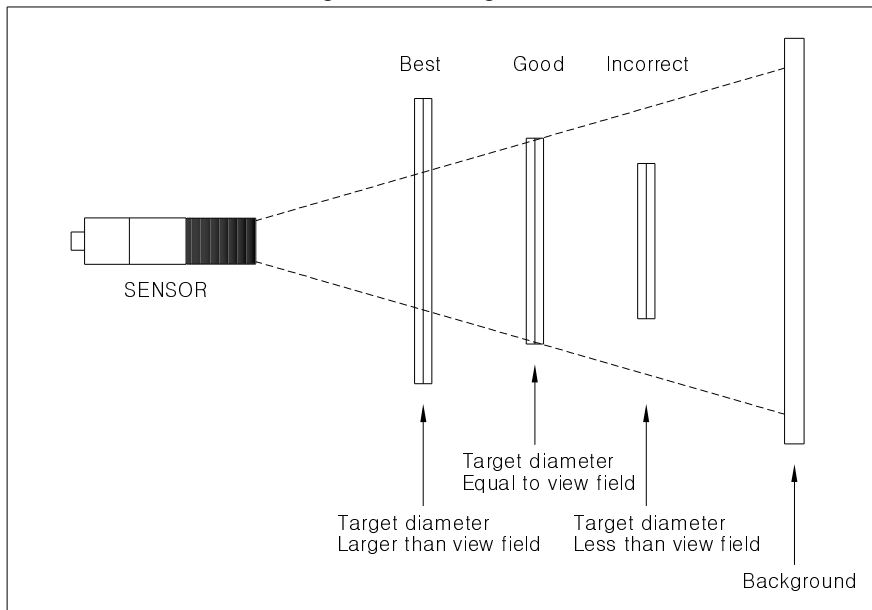

The spot size is decided by the distance from the sensor to the target.

Please refer to the 'section 5. Optical field of view' and make sure your target area is larger than the field of view.

- Please locate the sensor vertical against the target.

It is the best for you to install the sensor vertical against the target area or object. If it is not available, the sensor should be more than 45° against the target area. Otherwise, it can affect the measuring accuracy.

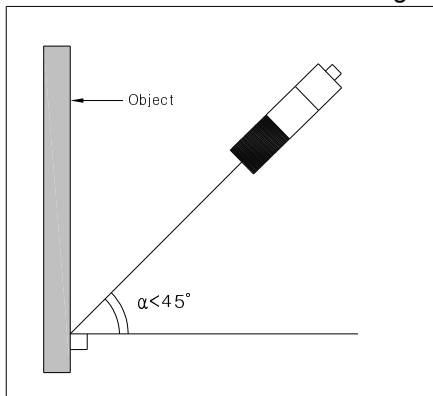

- Please avoid the heat reflection from other high temperature materials

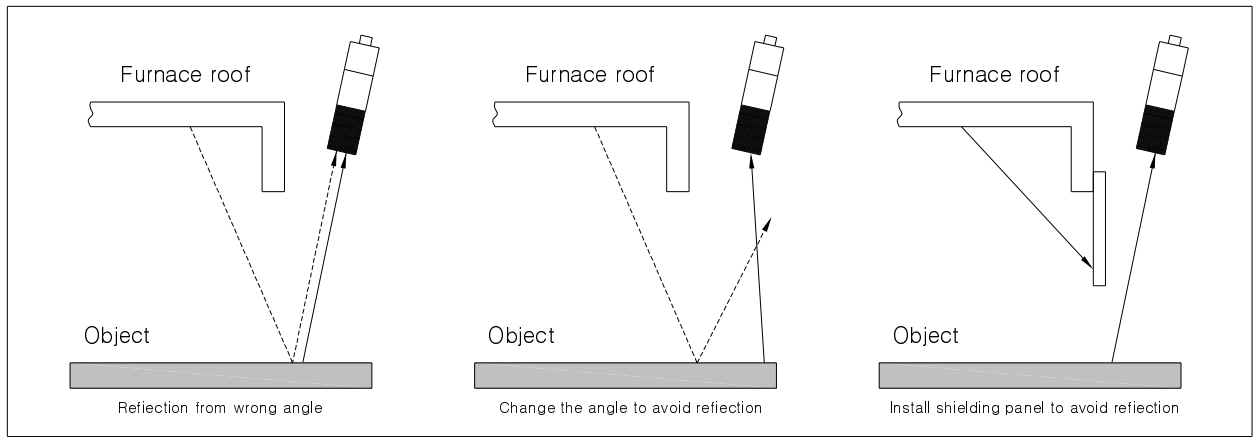

□ Please avoid highlight.

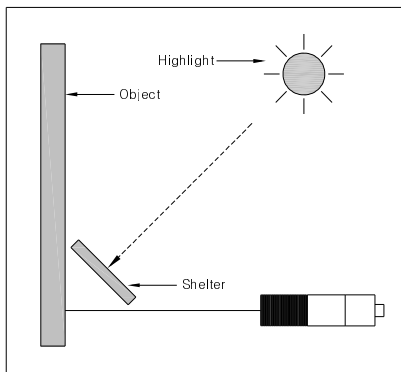

□ Please avoid electronic noise.

Please avoid the high frequency or high voltage area such as motor, pump, power line, and so on.

12. Emissivity Table

Appendix A – Emissivity Table for Metals

Material		Typical Emissivity
Aluminium	Non oxidized	0,02-0,1
	Polished	0,02-0,1
	Roughened	0,1-0,3
	Oxidized	0,2-0,4
Brass	Polished	0,01-0,05
	Roughened	0,3
	Oxidized	0,5
Copper	Polished	0,03
	Roughened	0,05-0,1
	Oxidized	0,4-0,8
Chrome		0,02-0,2
Gold		0,01-0,1
Haynes	Alloy	0,3-0,8
Inconel	Electro polished	0,15
	Sandblast	0,3-0,6
	Oxidized	0,7-0,95
Iron	Non oxidized	0,05-0,2
	Rusted	0,5-0,7
	Oxidized	0,5-0,9
	Forged, blunt	0,9
Iron, casted	Non oxidized	0,2
	Oxidized	0,6-0,95
Lead	Polished	0,05-0,1
	Roughened	0,4
	Oxidized	0,2-0,6
Magnesium		0,02-0,1
Mercury		0,05-0,15
Molybdenum	Non oxidized	0,1
	Oxidized	0,2-0,6
Monel (Ni-Cu)		0,1-0,14
Nickel	Electrolytic	0,05-0,15
	Oxidized	0,2-0,5
Platinum	Black	0,9
Silver		0,02
Steel	Polished plate	0,1
	Rustless	0,1-0,8
	Heavy plate	0,4-0,6
	Cold-rolled	0,7-0,9
	Oxidized	0,7-0,9
Tin	Non oxidized	0,05
Titanium	Polished	0,05-0,2
	Oxidized	0,5-0,6
Wolfram	Polished	0,03-0,1
Zinc	Polished	0,02
	Oxidized	0,1

Appendix B – Emissivity Table for Non Metals

Material		Typical Emissivity
Asbestos		0,95
Asphalt		0,95
Basalt		0,7
Carbon	Non oxidized	0,8-0,9
	Graphite	0,7-0,8
Carborundum		0,9
Ceramic		0,95
Concrete		0,95
Glass		0,85
Grit		0,95
Gypsum		0,8-0,95
Ice		0,98
Limestone		0,98
Paint	Non alkaline	0,9-0,95
Paper	Any color	0,95
Plastic >50µm	Non transparent	0,95
Rubber		0,95
Sand		0,9
Snow		0,9
Soil		0,9-0,98
Textiles		0,95
Water		0,93
Wood	Natural	0,9-0,95