



Infrared Thermometer Sensor

Smoke Sensor

TS-70

Temperature & Smoke Sensor

| Features

TS-70 is built-in Non contact Infrared thermometer and smoke sensor.

The most of existing temperature and smoke sensors in markets can detect fire after the heat reach to temperature and smoke detector.

However, TS-60 detects the fire by increased infrared amount and low concentrated smoke in early stage of the fire and enables to prevent the fire in advance.

| Dimension

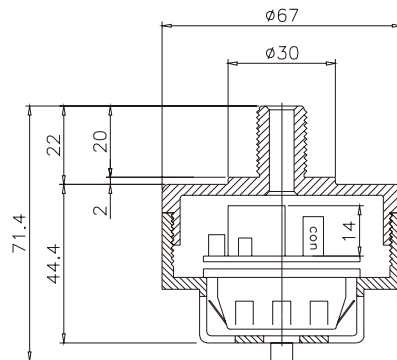

| Product Specification

Segment	Non-contact Infrared Thermometer
Measuring Range	-70~350°C (Alarm value setting by DIP Switch)
Device	Termopile (Non-contact Infrared Thermometer)
Optical Resolution	35 °
Optical Spectrum	8~14 μ m
Response Time	0.3sec
Relay Output	4~20mA or Relay Output

Segment	Smoke Sensor
Detection Principle	Ionizations Smoke Chamber
Detection Method	Diffusion
Response Time	Within 3 sec
Relay Output	Relay A (DC 30V 1A)
Input Power	DC 22~26V
Current Consumption	Maximum 50mA
Operating Temperature and Humidity	-20~60°C, 0~95% RH (Non-condensing)
Process	Digital Process



| Authorized Distributor